

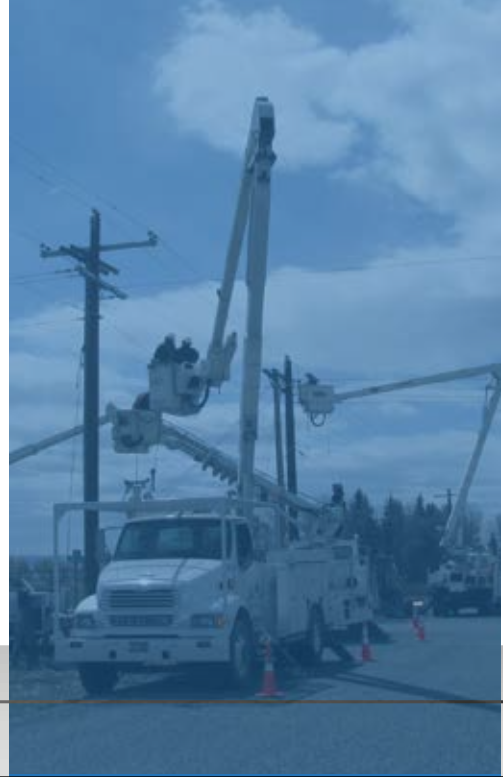

RURAL ELECTRIC COOPERATIVE

*Where Service Matters*



# Electric Service Requirements

*for Residential & Commercial Service*

*Committed to safely and economically provide reliable energy and other services which bring value to its membership.*

# ELECTRIC SERVICE REQUIREMENTS RESIDENTIAL AND COMMERCIAL

## Service Requirement Checklist

The following information summarizes the action required by both the member and Fall River Electric. Please read through these steps and provide the needed information and fees. This will speed the process, allowing us to serve you more efficiently.

1. **Physical Address:** Please have physical address of the service location.
2. **Line Extension Applications:** Please complete a Purchase of Power Agreement and submit to the Fall River Electric Engineering Department and pay applicable costs. An easement must be provided by owner.
3. **Service Location:** Please provide a service location on a site plan. If a plat has been done, one must be provided to Fall River Electric. In the case of a subdivision, an approved plat from Planning and Zoning will be required. The plan should depict the building(s) outline(s), any future building(s), the property layout, and location of the electric service.
4. **Electrical Drawings:** If applicable, please provide Fall River Electric with drawings which show service entrance equipment and distribution panel information.
5. **Load Estimates:** All customers shall provide estimated load information and voltage.
6. **New Accounts:** Applicants must become a member of Fall River Electric and establish an account for each new meter.
7. **Fees/Deposits & Construction Costs:** Applicant must pay in advance, prior to construction, all applicable fees, deposits, and construction costs.
8. **Inspections:** Home owners must contact the appropriate state agency for an electrical inspection of your electric installation.

Once the above items have been completed, Fall River Electric construction crews or contractors can schedule service construction.

Should you require more detailed information, please consult the appropriate section in this booklet or contact Fall River Electric's Engineering Department.

Engineering Department—208-652-7431 or 800-632-5726

## Welcome to the Fall River Rural Electric Cooperative, Inc. SERVICE AREA

Fall River Electric is committed to supplying its members with reliable electrical service. Every employee's goal is to serve the members who own the Cooperative. This is YOUR utility. We at Fall River Electric look forward to serving you.

Please contact Fall River Electric if you have any questions or need additional information not covered by this service requirements guide.

Main Office (Ashton) ..... (208) 652-7431  
..... (800) 632-5726  
1150 North 3400 East FAX (208) 652-7825  
Ashton, ID 83420

Office Hours 8:00 a.m. – 4:30 p.m.

Driggs Office .....(800) 632-5726  
1605 N. Highway 33  
PO Box 511.....FAX (208) 354-8343  
Driggs, ID 83422

Office Hours 8:00 a.m. – 4:30 p.m.

West Yellowstone Office..... (800) 632-5726  
436 Madison Ave ..... FAX (406) 646-4204  
PO Box 149  
West Yellowstone, MT 59758

Office Hours 8:00 a.m. – 4:30 p.m.

**INFORMATION FOR USE BY:**

- MEMBERS
- ARCHITECTS
- ENGINEERS
- CONTRACTORS
- ELECTRICIANS
- EXCAVATORS

AND THOSE ENGAGED  
IN THE PLANNING AND  
CONSTRUCTION OF  
ELECTRIC SERVICE AND  
METER INSTALLATIONS

*updated September 2017*



**TABLE OF CONTENTS**

	PAGE
<b>SECTION 1.0 GENERAL INFORMATION</b> .....	<b>2-3</b>
1.01 PURPOSE.....	2
1.02 CUSTOMER RESPONSIBILITY FOR SAFETY .....	2
1.03 WORK ACTIVITY NEAR POWER LINES .....	2
1.04 GROUNDING/BONDING.....	2
1.05 SERVICE AREA.....	2
1.06 APPLICATION FOR SERVICE.....	2
1.07 LOCATION OF SERVICE.....	3
1.08 TYPES OF SERVICE.....	3
1.09 CODES AND ORDINANCES.....	3
1.10 CHANGES OR CONFLICTS IN REQUIREMENTS.....	3
1.12 METER SEALS.....	3
<b>SECTION 2.0 SERVICES</b> .....	<b>4-5</b>
2.01 GENERAL.....	4
2.02 POINT OF DELIVERY.....	4
2.03 LOCATION OF METERS .....	4
2.04 TEMPORARY SERVICES .....	5
2.05 DISCONNECTION AND RECONNECTION OF SERVICE.....	5
2.06 RELOCATION OF SERVICES AND FACILITIES.....	5
2.07 MEMBER EQUIPMENT ON UTILITY POLES .....	5
2.08 CABINET AND GUTTER SEALS.....	5
<b>SECTION 3.0 OVERHEAD SERVICE</b> .....	<b>6</b>
3.01 SERVICE DROP.....	6
3.02 RESIDENTIAL OCCUPANCIES.....	6
3.03 MULTIPLE-FAMILY OVERHEAD SERVICE.....	6
3.04 OVERHEAD SERVICE TO MOBILE HOMES.....	6
3.05 NONRESIDENTIAL OVERHEAD SERVICE.....	6
<b>SECTION 4.0 UNDERGROUND SERVICE</b> .....	<b>7-9</b>
4.01 UG SERVICES.....	7
4.02 TRENCHES – YOU DIG 1-800-342-1585 or 811.....	7
4.03 CONDUIT.....	7
4.04 CLEARANCES FROM SWIMMING POOLS.....	8
4.05 UNDERGROUND SERVICE RESIDENTIAL OCCUPANCIES.....	8
4.06 UNDERGROUND SERVICE TO MOBILE HOMES .....	9
4.07 UNDERGROUND SERVICE TO MANUFACTURED HOMES WITH FACTORY INSTALLED METER BASES .....	9
4.08 NONRESIDENTIAL UNDERGROUND SERVICE.....	9
<b>SECTION 5.0 METER INSTALLATION</b> .....	<b>10-11</b>
5.01 GENERAL.....	10
5.02 ACCEPTABLE METER SOCKETS .....	10
5.03 MOUNTING OF METER SOCKETS.....	10
5.04 CURRENT TRANSFORMER METERING.....	11
5.05 SOCKET FOR REACTIVE DEMAND METER .....	11
5.06 METERING ON FALL RIVER ELECTRIC POLE.....	11
<b>SECTION 6.0 MEMBER EQUIPMENT AND DEVICES AND CHARACTER OF SERVICE</b> .....	<b>12-13</b>
6.01 GENERAL.....	12
6.02 SINGLE-PHASE SERVICE.....	12
6.03 THREE-PHASE SERVICE.....	12
6.04 MOTOR PROTECTION.....	12
6.05 MOTOR STARTING.....	12
6.06 INTERFERING LOADS .....	13
6.07 POWER FACTOR.....	13
6.08 EMERGENCY OR STANDBY GENERATORS.....	13
6.09 AVAILABLE FAULT CURRENT .....	13
<b>DRAWINGS</b> .....	<b>14-19</b>
<b>GLOSSARY</b> .....	<b>20-21</b>

# 1. GENERAL INFORMATION

## 1.01 PURPOSE

This booklet was prepared to aid you in establishing new or upgraded electric service. It does not include all of Fall River Electric's policies. We recognize that you may require personal assistance from our staff, and we would encourage you to contact us by calling your nearest Fall River Electric office to discuss your electric service requirements with us. Additional copies of this booklet are available at any of our offices. It is the goal of Fall River Electric to provide you, the member, with high-quality, safe electric service.

In order to avoid unnecessary repetition, the words "Fall River Electric" as used in the following pages shall mean Fall River Rural Electric Cooperative, Inc.

This booklet is intended to provide you, the member, with the necessary requirements to allow Fall River Electric to provide you electric service. The responsibility for the member's wiring and equipment remains with the member.

## 1.02 CUSTOMER'S RESPONSIBILITY FOR SAFETY

The customer shall comply with Federal, state, local laws, and Fall River Electric's regulations concerning activities in the vicinity of Fall River Electric's power lines and equipment. The customer shall comply with all laws and regulations to protect themselves, their family, their employees, Fall River Electric and its employees, and contractors and all third parties from injury, loss, or damage.

## 1.03 WORK ACTIVITY NEAR POWER LINES

State statute and Federal OSHA laws require that no work take place within 10 feet of a high-voltage overhead power line (some lines require even greater clearance). The following are two requirements:

1. The responsible party must notify Fall River Electric of the intended work activity a minimum of three working days prior to construction work. More lead time may be required depending on the work to be done.
2. The responsible party and Fall River Electric must agree to a mutually satisfactory method to accomplish the activity safely.

## 1.04 GROUNDING/BONDING

Grounding and bonding is critical for safety and electrical reliability. The customer is responsible to ensure that their electrical wiring and service equipment is grounded and bonded in accordance with applicable NEC requirements.

## 1.05 SERVICE AREA

Fall River Electric provides electricity to any applicant within its service area who is willing to become a member of the cooperative and abide by its Articles of Incorporation, bylaws, and policies.

## 1.06 APPLICATION FOR SERVICE

Fall River Electric is a non-profit electric cooperative corporation, and membership therein is a condition of receiving electric service. Membership is available upon application to individuals, husband and wife jointly, partnerships, associations, public or private corporations, or government organizations. A membership application is required at no fee. There will be a \$50.00 charge for a meter installation, which is billed on the first billing. New members also will pay a refundable deposit. In some instances, the waiver of this deposit is possible with an approved letter of credit from another utility.

The member will be requested to sign a Purchase of Power Agreement, provide easements and, if necessary, pay Aid to Construction or Advance on Construction, where applicable.

It will take approximately two weeks after receipt of the above items before construction will start. Since construction schedules change, the member can receive updates on their schedule by contacting the appropriate office or the Ashton office during normal business hours.

Prior agreement must be obtained from Fall River Electric for service to single or three-phase loads larger than 300 kilowatts.

## **1.07 LOCATIONS OF SERVICE**

Before providing any electrical service, Fall River Electric will determine the location for your meter equipment.

## **1.08 TYPES OF SERVICES**

Electric service available is 60-hertz, alternating current, single or three-phase. The normal voltages supplied by Fall River Electric to its members are given below. Service may be supplied by either overhead or underground distribution lines at these voltages.

Single-phase, 120/240 volts

Three-phase, 120/208 volts

Three-phase, 277/480 volts

Three-phase, 120/240 and 240/480 volts may be provided under special conditions.

## **1.09 CODES AND ORDINANCES**

It is necessary that the construction of new or upgraded installations conform to current and applicable provisions of the National Electric Code, the National Electrical Safety Code, Federal and State regulations, as well as Fall River Electric policies.

## **1.10 CHANGES OR CONFLICTS IN REQUIREMENTS**

Prior to the service being connected, proper state and county building permits and state electrical permits must be obtained. Some of the information contained in this booklet is based on state and national codes and is subject to change. Fall River Electric may be consulted on the applicability of any item.

## **1.11 EASEMENTS**

Fall River Electric will construct, own, operate, and maintain facilities only on easements or rights-of-way satisfactory to Fall River Electric. As condition of service, Fall River Electric will require the execution of an easement, or easements, providing suitable right-of-way for the construction and maintenance of the distribution lines. Easements are to be kept clear of all obstacles restricting access for maintaining the electrical facilities. Trees will be trimmed or removed, as necessary, within the 20' right-of-way.

## **1.12 METER SEALS**

The purpose of seals placed by Fall River Electric on meters and associated service equipment is to prevent injury and/or tampering.

Seals are not to be removed except by Fall River Electric. If an emergency should require seal removal without prior notification, Fall River Electric must be notified as soon as possible, so the installation can be inspected and the seal replaced.

# 2. SERVICES

## 2.01 GENERAL

The location of the service entrance on the member's premises is an important consideration to both the member and Fall River Electric. The service entrance shall be located to make the meter and service easily accessible from Fall River Electric distribution lines and convenient for the installation, operation, and maintenance of meters and equipment. Fall River Electric shall be consulted in order to designate the point of attachment for all service equipment.

For secondary voltage service, Fall River Electric will provide, install, and maintain transformers, meters, and service drop or lateral conductors. The member will provide, install, and maintain all service equipment, including switches, raceways or conduit, enclosures, meter sockets, and ground rods, and will provide right-of-way and access for the installation and maintenance of Fall River Electric's facilities.

Normally, a building will be supplied with electricity through only one set of main service conductors.

For your safety, only authorized Fall River Electric representatives shall make the permanent connection or disconnection of Fall River Electric's electric service to a building or structure.

## 2.02 POINT OF DELIVERY

The "point of delivery," unless otherwise specified by Fall River Electric, is that location where the Cooperative's circuit and the member's system are interconnected. The exact location of the point of delivery and metering equipment will be determined by Fall River Electric.

Consumer is to provide the conduit from the transformer to point of delivery. Fall River Electric will provide all poles, pole attachments, transformers, transformer pads (except field poured), service conductor, meters, and primary voltage facilities. These construction materials will be charged to the consumer on the estimate, as applicable.

## 2.03 LOCATION OF METERS

Suitable space and provisions for mounting meters must be provided by the member at a location acceptable to Fall River Electric and which is accessible to a Fall River Electric representative at all times. The minimum unobstructed wall space for a single meter is 14 x 30 inches. No foliage may be planted within 6 feet of meters or pad mounted transformers (see Drawing SR-1, SR-2, SR-3, SR-20, SR-21).

On ganged meter installations, the distance from the outside of the enclosure shall not be less than 7 inches from a wall or obstruction (see Drawing SR-1). Additional wall space for instrument transformers may be required when the capacity of the service entrance exceeds 200 amperes, three-phase, or 320 amperes, single-phase. The size of the space required will also be larger when more than one meter is required.

A 6 foot working space shall be maintained in front of self-contained metering installations and instrument transformer cabinets. Meter and metering equipment must be a minimum of 60-inches horizontally from a gas meter (see Drawing SR-2).

The meter socket shall be 5 to 7 feet above the finished grade or floor immediately in front of the meter. Meter sockets in mobile home pedestals shall not be less than 42 inches above finished grade (see Drawing SR-3). Meters in pedestals should be suitably protected from physical damage.

All meters must be installed outdoors at a location that is readily accessible to Fall River Electric employees. The meter should be located on the side of the structure closest to Fall River Electric lines or within 10 feet of that side. In

heavy snow fall areas, it is recommended using the gable end of the structure. It is recommended that electrical code specifications on placement of meters be followed.

All meters shall be located outdoors unless Fall River Electric confirms, prior to installation, that an acceptable outdoor location is not available. An indoor meter must be accessible to Fall River Electric employees during daytime working hours. (Locked meter rooms are not considered to be accessible unless keyed for a Fall River Electric lock.)

If, in the opinion of Fall River Electric, a meter is made inaccessible, such as by the installation of a fence or enclosure, the member shall, at their expense, move the meter socket to an accessible location.

## **2.04 TEMPORARY CONSTRUCTION SERVICES**

Power to a member owned temporary construction service may be supplied when requested. State inspection is required before connection can be made. Fall River Electric will energize only after the permit has been paid to the state.

Temporary services for construction work must be located such that the meter is protected from mechanical injury. Should relocation of a temporary service become necessary, the relocation cost will be borne by the Contractor or member (see Drawing SR-4 and SR-5).

## **2.05 DISCONNECTION AND RECONNECTION OF SERVICE**

For safe working conditions, Fall River Electric will disconnect and reconnect any service supplying member-owned service equipment that must be de-energized prior to modification. There will be no charge for the disconnection if done during normal work hours. The reconnection will be done without charge if it can be completed on the initial trip or on a second trip scheduled during regular working hours, and at Fall River's convenience; otherwise, the member will be billed a reconnection charge according to the fee schedule then in effect.

Any modifications to metering equipment will require a state electrical inspection. Fall River Electric cannot reconnect unless the modifications have been certified by the State. (For your safety, only authorized Fall River Electric representatives will disconnect or reconnect facilities.)

## **2.06 RELOCATION OF SERVICES AND FACILITIES**

If a member requests a relocation of Fall River Electric's facilities, there will be a charge for such relocation.

## **2.07 MEMBER EQUIPMENT ON UTILITY POLES**

Member-owned metering equipment switching devices, conduits, conductors, etc. can be mounted on Fall River Electric's poles when permission is granted by Fall River Electric.

## **2.08 CABINET AND GUTTER SEALS**

All cabinets and gutters containing unmetered conductors must be sealed with a Fall River Electric seal.

# 3. OVERHEAD SERVICE

## 3.01 SERVICE DROP

In areas served from overhead lines, an overhead service drop will be installed by Fall River Electric from Fall River Electric's distribution line to the service entrance conductors of the member's service equipment.

The point of attachment shall be high enough above both initial and finished grade and in a proper position to provide not less than minimum NESC clearances. The route of the service drop must be without obstruction by buildings, trees, or other objects. The point of attachment will normally be on the building wall facing the nearest Fall River Electric line or on a service mast capable of withstanding the tension of the service drop. Supports for service drops must be extended from and tied into the main structural supports of the building. The service mast should extend through the roof on a typical single-story building (see Drawing SR-16).

If a member encounters problems in determining these clearances, Fall River Electric will aid in determining specific requirements that will comply with the code.

## 3.02 RESIDENTIAL OCCUPANCIES

It is the responsibility of the member to bring the service entrance conductors to Fall River Electric's service drop. Fall River Electric will make the final electrical connection.

## 3.03 MULTIPLE-FAMILY OVERHEAD SERVICE

Fall River Electric prefers the grouping of service heads at a common location and will not extend service drop conductors from the point of attachment to the individual weather heads. It will be the member's responsibility to bring his service entrance conductors to Fall River's service drop. If more than one service drop to a building is required, it will be the member's responsibility to obtain permission from the electrical code enforcing authority having jurisdiction.

Where two or more meters are grouped, each meter position must be clearly and permanently identified by means of a metal or hard plastic engraved type label to indicate the location supplied by the meter. Service will not be established until the marking is completed. Unmetered service wires and metered load wires shall not be run in the same conduit, raceway, or wiring gutter.

## 3.04 OVERHEAD SERVICE TO MOBILE HOMES

The member must install the meter base and service equipment on a wood pole purchased from Fall River Electric. The pole will be installed by Fall River Electric not more than 30 feet from the mobile home.

## 3.05 NON-RESIDENTIAL OVERHEAD SERVICE

Where more than one service entrance of the same voltage and phase to a building is necessary, the service entrance(s) must be grouped so they may be served from the same set of service drops.



# 4. UNDERGROUND SERVICES

## 4.01 UNDERGROUND SERVICES

Before making any preparation for underground service, the member or his representative must obtain approval and specifications from Fall River Electric covering the proposed installation and the member's responsibilities. Member must provide finish grade level for transformer location. All underground services are to be installed to finish grade.

Members adequately served by existing overhead distribution facilities, but desiring underground service will pay for all costs.

## 4.02 MEMBER TRENCHES AND CONDUIT

### Call Before You Dig

Idaho (Phone 811 or 1-800-342-1585)

Montana (Phone 811 or 1-800-424-5555)

Wyoming (Phone 1-800-549-2476 or 1-307-232-8775)

**If member is providing a trench for service conduit, refer to drawings SR-18A, SR-7B.** When digging trench up to existing transformer for new service, find front of transformer (will have pentahead bolt with padlockable hasp or handle with lock). Standing looking at the front of transformer, dig to the right side of transformer. The last 2 feet must be done with hand shovel to avoid damaging any existing wire. Expose fiberglass box under transformer to full depth. Fall River Electric will finish installing conduit.

**If the member is providing the trench for Fall River Electric to install the cable and conduit system in,** Idaho law requires that all utilities be notified at least two full working days prior to excavation, and that excavation must not be started until locates have been made or the utility has notified the excavator that they have no facilities in the area. When you are ready to provide your service trench, please contact the Operations Department during regular working hours. They need a minimum of three working days advance notice before you trench to allow for scheduling. If the crew can't complete the work because the member wasn't ready, then additional charges are necessary.

**Depth** - The trench shall be a minimum of 38 inches deep for high voltage primary (prior authorization from Fall River Electric is required to install primary cable), and a minimum of 24 inches deep for low voltage secondary. If depth requirements are not possible, please contact Fall River Electric's Engineering Department for alternatives (see Drawing SR-18, SR-18B).

**Backfill** - The member will be responsible for backfilling the trenches. The selected backfill material must not contain any sharp or foreign objects. Selected backfill around the direct buried cable must be sand, loam, or other approved rock-free material. Place the backfill material 4 inches above and below the cable. Contact Fall River Electric for the method to be used to protect conductors to be placed in rocky ground. Conductors shall not be energized until backfill is complete (see Drawing SR-18).

**Joint Use** - Telephone, cable TV, and other electrical conductors may be placed in the same trench as Fall River Electric's conductors, provided that the installation is in accordance with NESC and Fall River Electric minimum specifications and is mutually agreed to by all parties concerned.

**Width** - Trenches shall be a minimum of 18 inches wide, unless a narrower width is approved by Fall River Electric. Consult Fall River Electric if an 18 inch trench cannot be obtained (see Drawing SR-18).

Fall River Electric will not install electrical conductors in a common trench with non-electric utilities such as water, gas, and sewer, unless unusual conditions such as adverse soil or route restrictions exist. All such installations require the prior written approval of Fall River Electric.

## 4.03 CONDUIT

All exposed conduit above ground shall be Gray Schedule 80; conduit underground may be Gray Schedule 40 or 80. Install pull string (pull strength up to 50 lbs) and seal open ends of the pipe to prevent any birds from entering.

# 4. UNDERGROUND SERVICES (continued)

Consumer will install all underground raceways and conduit systems at his cost, in member provided trenches, and connect this conduit system to member provided surface mounted meter base or CT cabinet (see Drawing SR-7A, SR-7B-1, SR-8, SR-9, SR-14, SR-18B). Any exception must be approved by Fall River Electric in advance. At the transformer, the consumer will leave elbow and conduit to go into the transformer. Fall River Electric will install conduit into the transformer box.

## 4.04 CLEARANCES FROM SWIMMING POOLS

Underground raceways and conductors shall not be located under a swimming pool or within 10 feet of the inside wall of a pool.

## 4.05 UNDERGROUND SERVICE – RESIDENTIAL OCCUPANCIES

For underground service to residential occupancies, including single and multiple-family dwellings and mobile-home parks, Fall River Electric's underground conductors are required to be installed in raceways or conduit systems, Fall River Electric limits the conduit bends to not more than 270 degrees and 250 feet long, which includes bends at the transformers and metering equipment. Fall River Electric charges for furnishing and installing conduit and conductor. The member or developer will be responsible for the cost of conduit and conductor, and all trenching, sand, excavation, and backfill on the premises or within the confines of the projects or subdivision to be served and, in some cases, for a distance outside the project to connect to Fall River Electric facilities. If consumer does not want to provide conduit, he may install a meter point with appropriate system protection at the transformer and direct bury secondary cable.

Where a pad mounted transformer is installed in a location where it might be struck by a motorized vehicle, the member is to provide, install, and maintain Fall River Electric approved barrier posts to protect the transformers (see Drawing SR-3A). Proper clearances must be maintained for pad mounted transformers and equipment (see Drawing SR-7).

The underground service lateral will be installed, owned, and maintained by Fall River Electric from Fall River Electric's distribution facilities line to the member's point of delivery. Fall River Electric limits the length of secondary voltage service runs to 250 feet or as limited by voltage drop and conductor losses.

### (A) 200 Amp or Less Rated Services

Fall River Electric will pull underground service conductors through conduit system and make appropriate electrical connections.

### (B) 320 Amp Rated Services

For single-phase service entrance equipment with a code-calculated load of up to 320 amperes, a 320 ampere, continuous rated surface mounted meter socket may be installed. Fall River Electric will connect the service lateral on the line side of the meter socket if the socket conforms to Electric Utility Service Equipment Requirements Committee EUSERC 302 (see Drawing SR-11). - Lever by-pass Required

### (C) Greater Than 320 Amp Services

Consult Fall River Electric Engineering Department.

For code-calculated loads greater than 320 amperes, current transformer metering will be required. The member is to provide and install a current transformer cabinet. This cabinet should be located on the exterior of the building or approved mounting post. If no satisfactory exterior location is available, by special permission of Fall River Electric, the cabinet may be located inside the building (see Article 5.04 for cabinet size; see Drawing SR-9).

**In cases where the customer is extending the service drop more than 50 feet from the current transformer cabinet to load center, Fall River Electric requires a (fuse) disconnect switch on each lateral or (fuse) disconnect for total load.**

Where a current transformer cabinet is installed from underground service, Fall River Electric will connect the service conductors on the current transformer mounting base (see Drawing SR-9).

## **4.06 UNDERGROUND SERVICE TO MOBILE HOMES**

For underground service to a mobile home, the member's service entrance equipment must be located in a pedestal approved from the purpose. When the meter may be subject to physical damage, barrier posts or other suitable protection must be installed and maintained by the member.

Consumer will install a conduit system to meter pedestal in member furnished trench. Fall River Electric limits the conduit bends to not more than 270 degrees, which includes bends at transformers and metering equipment. Fall River Electric will make service conductor termination after member's service equipment has been certified by a state inspection.

Raceways and conduits in mobile home parks must be provided for Fall River Electric conductors and must be located so as to avoid passing under the pad, foundation, or area provided for the mobile home.

## **4.07 UNDERGROUND SERVICE TO MANUFACTURED HOMES WITH FACTORY INSTALLED METER BASES**

Underground service to manufactured homes, with factory installed meter bases, will be provided under the same requirements as residential occupancies (Article 4.05) provided the home is site specific, occupies a private lot, and has a permanent base.

## **4.08 NON-RESIDENTIAL UNDERGROUND SERVICE**

For underground service to commercial or industrial buildings or projects, the member or developer is responsible for all trenching and backfilling within the project. If a transformer installation is necessary, the member is to provide space for the transformer which meets the requirements of Fall River Electric. Consult with Fall River Electric for specific applications.

Where a pad mounted transformer, current transformer enclosure, or other equipment is installed in a location where it might be struck by a motorized vehicle, the member is to provide, install, and maintain Fall River Electric approved barrier posts to protect this equipment (see Drawing SR-3A). Fall River Electric will install necessary conduits and raceways at unit cost, in member furnished trench. Any exception must be approved by Fall River Electric in advance.

### **(A) 200 Amp or Less Rated Service**

Fall River Electric will pull underground service conductors through conduit system and make appropriate electrical connections. Fall River Electric will determine whether it is acceptable to pull cables prior to backfilling of trench, though cables will not be energized until the trench has been backfilled. Service lateral will be connected within the meter base by Fall River Electric after member installed equipment has been certified by a state inspection.

### **(B) 320 Amp Rated Services**

For single-phase service entrance equipment with a code-calculated load of up to 320 amperes, a 320 ampere, continuous rated surface mounted meter socket is required. Fall River Electric will connect the service lateral on the line side of the meter socket if the socket conforms to EUSERC 302.

The member's point of delivery must be located on the outside of the building, meter pedestal or service pole as shown on Drawings SR-2, SR-3, and SR-6. The member or Contractor should contact Fall River Electric for the location and routing of the service lateral prior to the start of building construction.

### **(C) Greater than 320 Amp Services**

In cases where the customer is extending the service drop more than 50 feet from the current transformer cabinet to load center, consult Fall River Electric Engineering Department.

# 5. METER INSTALLATION

## 5.01 GENERAL

Fall River Electric's rate schedules require that each class and type of electrical service must be separately metered.

Members are not authorized to relocate any meter belonging to Fall River Electric or interfere in any way with the meter or its connection.

The member is responsible to provide and install an exterior mounted approved meter base. When a three-phase service exceeds 200 amps, or for a single-phase service that exceeds 320 amps, an exterior mounted current transformer cabinet with mounting rack is required in addition to the required meter base as shown on Drawings SR-12.

## 5.02 ACCEPTABLE METER SOCKETS

Acceptable meter sockets are ones manufactured in accordance with the current standards of the American National Standards Institute (ANSI) and Underwriters Laboratory (UL). The meter socket, complete with terminal lugs, meter jaws, manual circuit-closing devices, when required, and provision for sealing, shall be provided by the member. All conductors are to enter and leave the enclosure through the appropriate openings. All meter sockets shall be ring type complete with sealable ring.

Services requiring current capacity greater than 320 amperes will need to be metered through current transformers. It is the member's responsibility to procure and install the current transformer cabinet and bar type rack.

The member's meter base needs to conform to the following:

- 3 wire single phase 200 amp or less uses a 4 jaw base.
- 3 wire single phase 320 amp uses a 4 jaw base with lever bypass.
- 4 wire three phase 200 amp or less uses a 7 jaw base with lever bypass.
- 4 wire three phase greater than 200 amp uses a 13 jaw base with bypass or test switch.

## 5.03 MOUNTING OF METER SOCKETS

Sockets must be level and square in all directions and securely mounted to a rigid surface. Conductors must be securely fastened to their respective terminals and must be arranged in a manner which will not interfere with the installation of the meter or cover or with the operation of a circuit-closing device.

Meter sockets mounted on buildings must have clearances as shown on Drawing SR-1 and SR-2. Fall River Electric requires 6 feet of clear working space in front of live parts. No barrier shall be installed that will be within 6 feet of the front of the meter panel. Meter sockets and other metering equipment must be located at least 60 inches horizontally from a gas meter.

If subject to physical damage, the meter shall be adequately protected.

Fall River Electric does not allow enclosures over meters.

## 5.04 CURRENT TRANSFORMER METERING

Current transformer metering is required where the ampacity of three-phase service entrances exceeds 200 amperes and the ampacity of single-phase entrances exceeds 320 amperes. Mounting base to accept bar-type current transformer only.

A weather-tight, lockable steel current transformer cabinet with terminal lugs, provided by the member, will be securely mounted on a rigid surface. This cabinet is to contain only the service conductors and Fall River Electric equipment. It is to be mounted in a readily accessible location acceptable to Fall River Electric. The current transformers will be provided by Fall River Electric. The acceptable minimum-size current transformer cabinets are:

TYPE OF SERVICE	MINIMUM CABINET SIZE W X H X D	MOUNTING BASE
3 Wire (Single-Phase) Greater than 320 Ampacity	30" x 36" x 11"	2 CT Base, EUSERC 328
3 or 4 Wire (Three-Phase) 201-800 Ampacity	36" x 48" x 11"	3 CT Base, EUSERC 329
Above 800 Ampacity (all facilities)	Consult Fall River Electric	Consult Fall River Electric

(see Drawing SR-9).

In the case of an upgrade of an existing service where limited space makes installation of standard-size boxes impractical, consult Fall River Electric to determine the size of an acceptable box which will meet all code requirements.

Fall River Electric will provide the meter socket and the conduit between the current transformer cabinet and meter socket. Conduit will be limited to maximum runs of 50 feet with not over 270 degrees in bends; no means that allow access to the wiring are permitted. All unprotected conduit runs shall be metallic with a minimum diameter of ¾ inch or Schedule 80 PVC. Only Fall River Electric conductors will be permitted in metering conduit. Meter may be located on current transformer cabinet (see Drawing SR-1A and SR-2A).

## 5.05 SOCKET FOR REACTIVE DEMAND METER

If reactive metering is required by Fall River Electric, a 13 jaw meter base will be installed.

## 5.06 METERING ON FALL RIVER ELECTRIC POLE

Fall River Electric may provide a pole for member installed metering equipment in accordance with the policy and schedule of charges (see Drawings SR-13 and SR-15).

# 6. MEMBER EQUIPMENT AND DEVICES AND CHARACTER OF SERVICE

## 6.01 GENERAL

The member's electrical equipment and devices are to have characteristics such that Fall River Electric's distribution system is efficiently utilized and undue interference with Fall River Electric service to other members does not occur.

The member's equipment shall be designed to perform satisfactorily within the standard voltage ranges and frequency provided on Fall River Electric's system. Fall River Electric will endeavor to maintain standard voltages and frequency on its distribution systems, subject to variations within reasonable limits.

Fall River Electric reserves the right to inspect and test any equipment connected to its lines and to require any information necessary to determine the operation characteristics of the equipment. The member shall submit information to Fall River Electric regarding any equipment which might cause interferences with service to other members, or require additional facilities for its satisfactory operation.

Electric service supplied by Fall River Electric may be subjected to voltage disturbances which will not normally affect the performance of lighting, appliances, heating, motors or other typical electrical equipment, but may result in the improper operation of voltage-sensitive equipment such as computers or microprocessors. Voltage-sensitive equipment is defined as equipment which is adversely affected by power disturbances (i.e. sags, spikes, harmonic interruptions). It is the responsibility of the member to provide any power conditioning devices that may be required to provide the quality of "power" necessary for optimum performance of his voltage-sensitive equipment.

## 6.02 SINGLE-PHASE SERVICE

Service shall be 120/240 volt and the load shall be balanced on the ungrounded conductors as closely as practical.

## 6.03 THREE-PHASE SERVICE

Three-phase service, if available, will normally be provided in accordance with Fall River Electric's current policies.

The manner in which single-phase load is connected by the member is critical with three-phase service. On 208Y/120 volt or 480Y/277 volt three-phase services, all single-phase loads should be split evenly among the three phases.

Three-phase service, if available, will be supplied to members upon request, provided three-phase service is necessary, such as to operate a motor larger than 10 horsepower.

Soft start required on any motors over 50 HP.

## 6.04 MOTOR PROTECTION

To assure adequate safety to personnel and equipment, it is recommended that the member provide and maintain code-approved protective devices to protect motors against overloading, short circuits, ground faults, and low voltage, and to protect all three-phase motors against single-phasing.

## 6.05 MOTOR STARTING

Reduced-voltage starters are usually required on all motors rated in excess of 50 horsepower.

Upon request and following evaluation, authorization may be granted by Fall River Electric to omit the reduced-voltage starter.

No additional Fall River Electric facilities will be installed to reduce voltage fluctuations on an individual member's service, caused by starting of motors, until after approved reduced-voltage starters have been installed by the member. If additional facilities are required, they will be installed at the member's expense.

## 6.06 INTERFERING LOADS

Whenever a member's utilization equipment has characteristics which cause undue interference with Fall River Electric's service to other members, the member shall make changes in such equipment or provide, at member expense, additional equipment to eliminate the interference.

Additional facilities such as separate Fall River Electric transformers and a separate service can be used to minimize voltage fluctuations on secondary voltage circuits for devices such as welders, induction heating equipment, and X-ray machines. Where the operation of this type of equipment causes undue voltage fluctuations on Fall River Electric's primary voltage lines, the additional equipment required may include a separate primary voltage line.

High-frequency equipment such as electronic heating equipment, spark discharge devices, radio transmitting equipment, etc., and equipment that generates harmonics, such as variable speed motor drives, shall be designed and operated so as not to create disturbances on Fall River Electric's electrical system which might interfere with the proper operation of communication, radio, television, remote control, or other utilization equipment of other members. Power quality shall meet the IEEE 519 standard.

## **6.07 POWER FACTOR**

The current Fall River Electric rate schedules specify a charge or excessive reactive demand. Low power factor may cause inferior performance of the member's electrical system. It is recommended that the member install corrective devices to make the most effective use of the electrical system.

## **6.08 EMERGENCY OR STANDBY GENERATORS**

Permanently installed emergency or standby generators are to be connected to the member's wiring system by a permanently installed transfer switch intended for that purpose. The transfer switch is to disconnect all ungrounded conductors connected to Fall River Electric's system prior to connecting the generator to the conductors supplying the load. The transfer switch is to be designed and installed so that connection of the generator to Fall River Electric's system is prevented for any mode of operation. Compliance with these provisions is necessary to prevent serious or possibly fatal accidents. Portable generators shall not be connected to a permanent wiring system at any time, unless the interconnection is made with a permanently installed transfer switch.

All transfer switches and/or transfer operating schemes must meet applicable building codes and pass appropriate inspections.

## **6.09 AVAILABLE FAULT CURRENT**

Upon request, Fall River Electric will supply the information on available fault current at the servicing transformer. It is the member's responsibility to furnish equipment which will withstand that fault current.

# SERVICE REQUIREMENT DRAWINGS

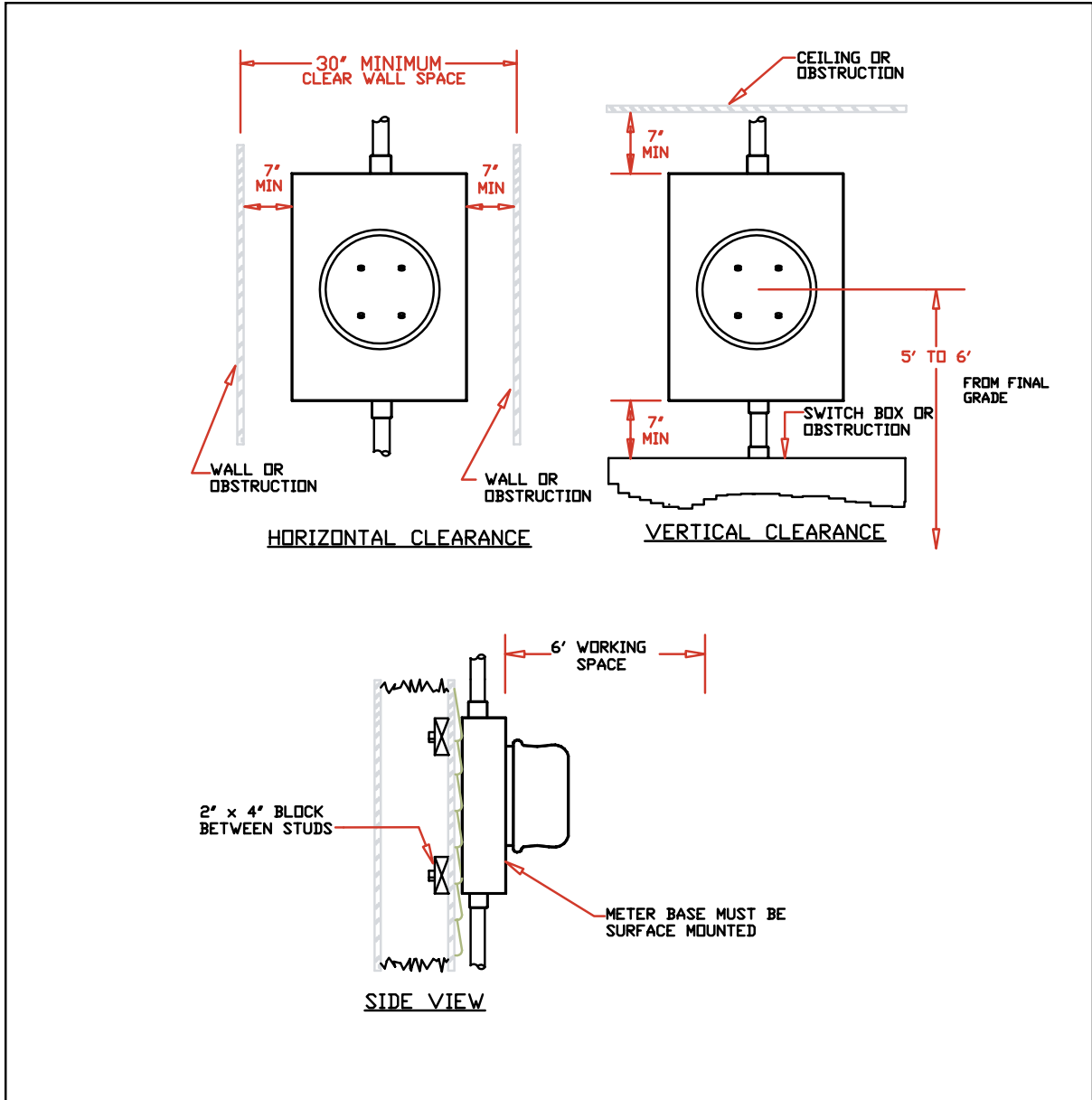

Scale:	No Scale	METER SOCKET CLEARANCE REQUIREMENTS	FALL RIVER ELECTRIC
Revision Date:	3/25/96		
Drawn by:	C. Isley		
Drawing Name:	SR-1.DWG		Page: SR-1

Sheet 1 of 1

## SR-1. METER SOCKET CLEARANCE REQUIREMENTS



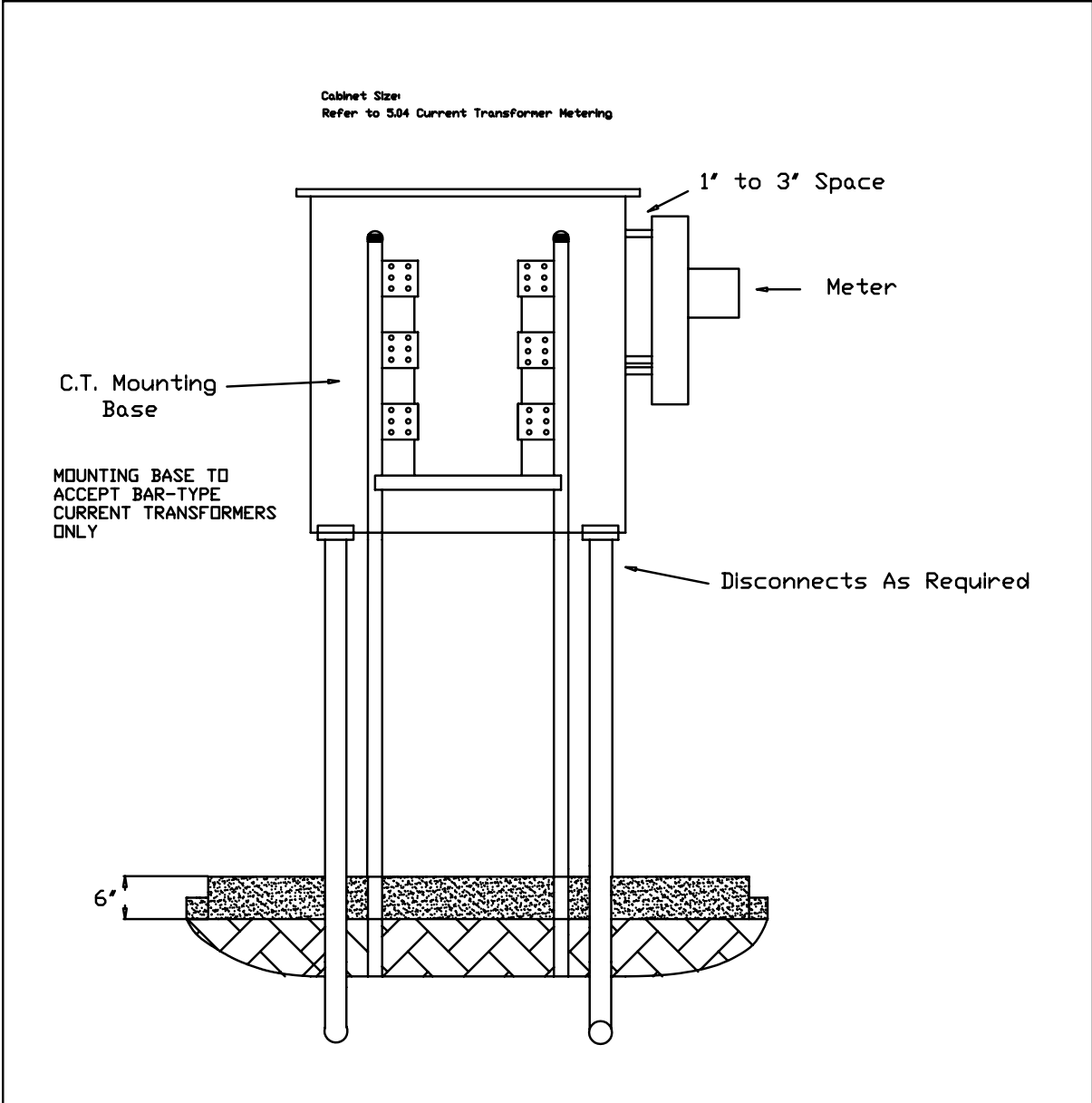

Scale: No Scale	CURRENT TRANSFORMER CABINET	FALL RIVER ELECTRIC
Revision Date: 7/14/97		
Drawn by: R. HATHAWAY		Page:
Drawing Name: SR-1A		SR-1A
Sheet 1 of 1		

**SR-1A. CURRENT TRANSFORMER CABINET**

# SERVICE REQUIREMENT DRAWINGS

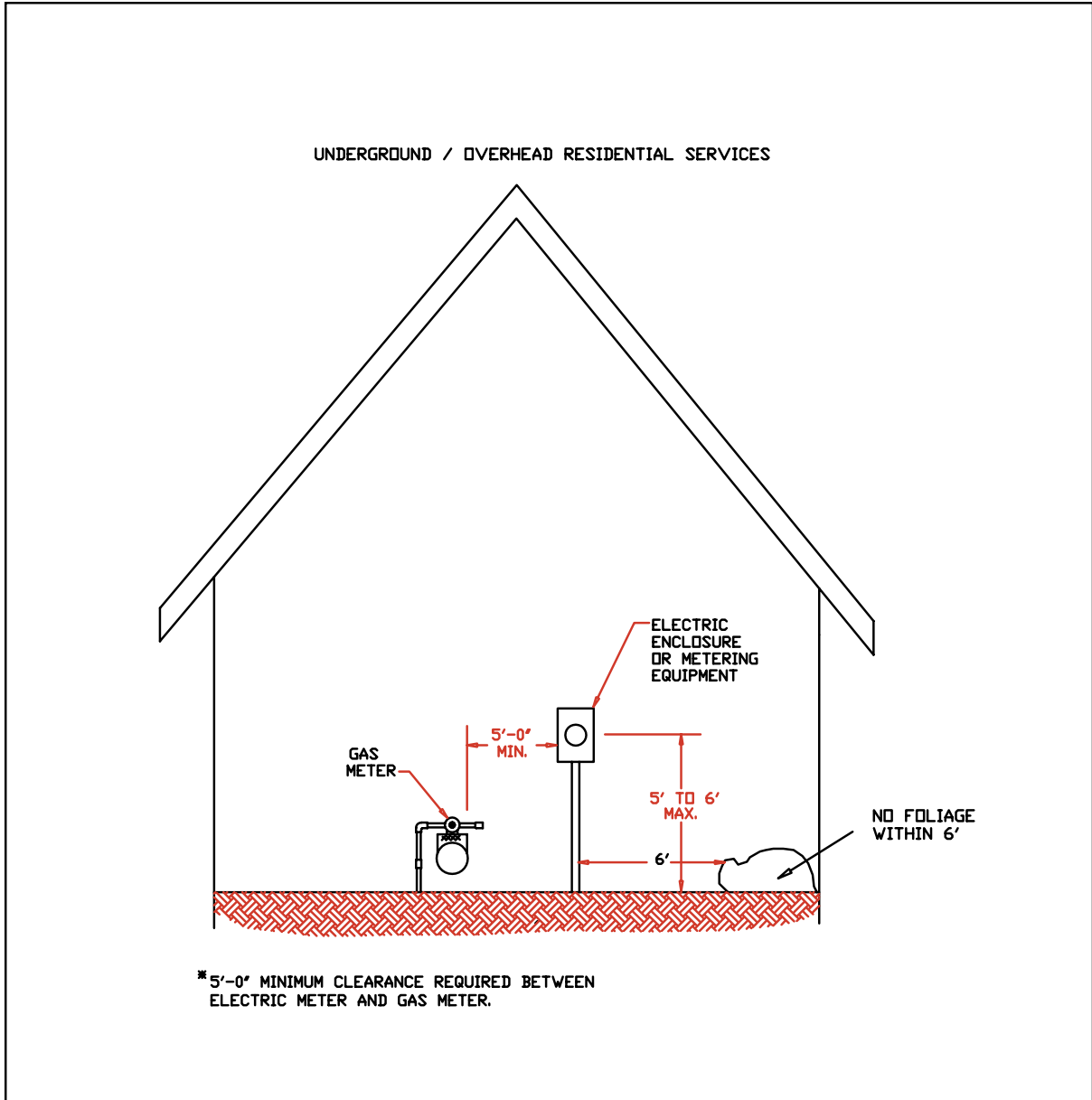

Scale:	No Scale	CLEARANCE BETWEEN ELECTRIC METER BASE AND GAS METERS	FALL RIVER ELECTRIC
Revision Date:	5/17/96		
Drawn by:	C. Isley		SR-2
Drawing Name:	SR-2		
		Sheet 1 of 1	Page: SR-2

**SR-2. CLEARANCE BETWEEN ELECTRIC METER BASE AND GAS METERS**

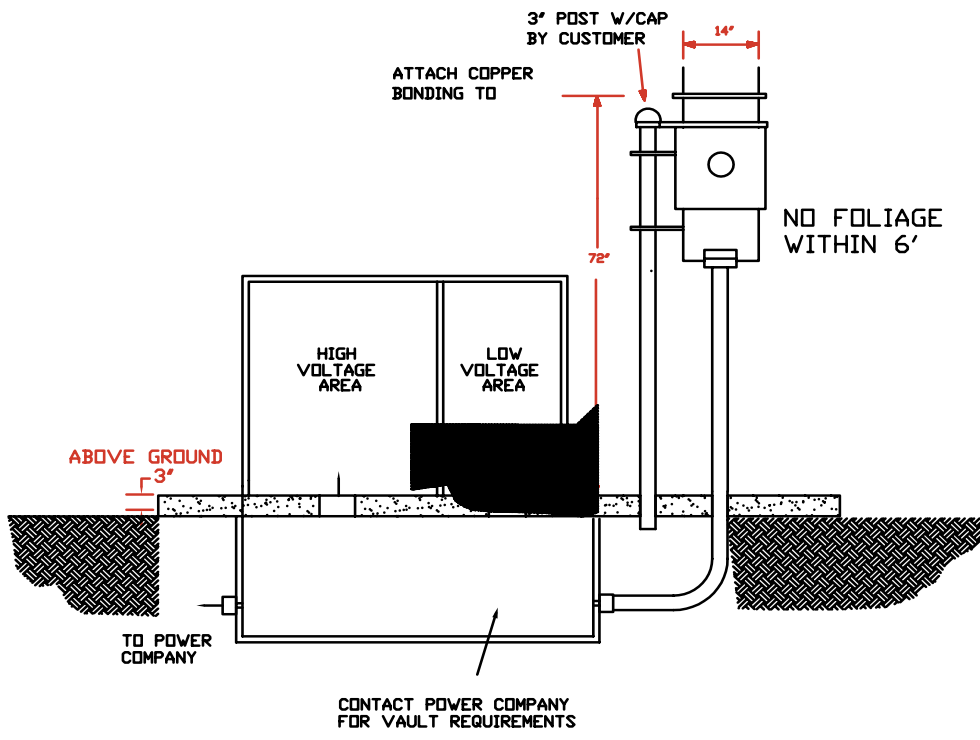

Scale:	No Scale	CURRENT TRANSFORMER METERING PADMOUNTED TRANSFORMER	FALL RIVER ELECTRIC
Revision Date:	3/07		
Drawn by:	LB		
Drawing Name:	SR-2A		Page: SR-2A

Sheet 1 of 1

**SR-2A. CURRENT TRANSFORMER METERING PADMOUNTED TRANSFORMER**

# SERVICE REQUIREMENT DRAWINGS

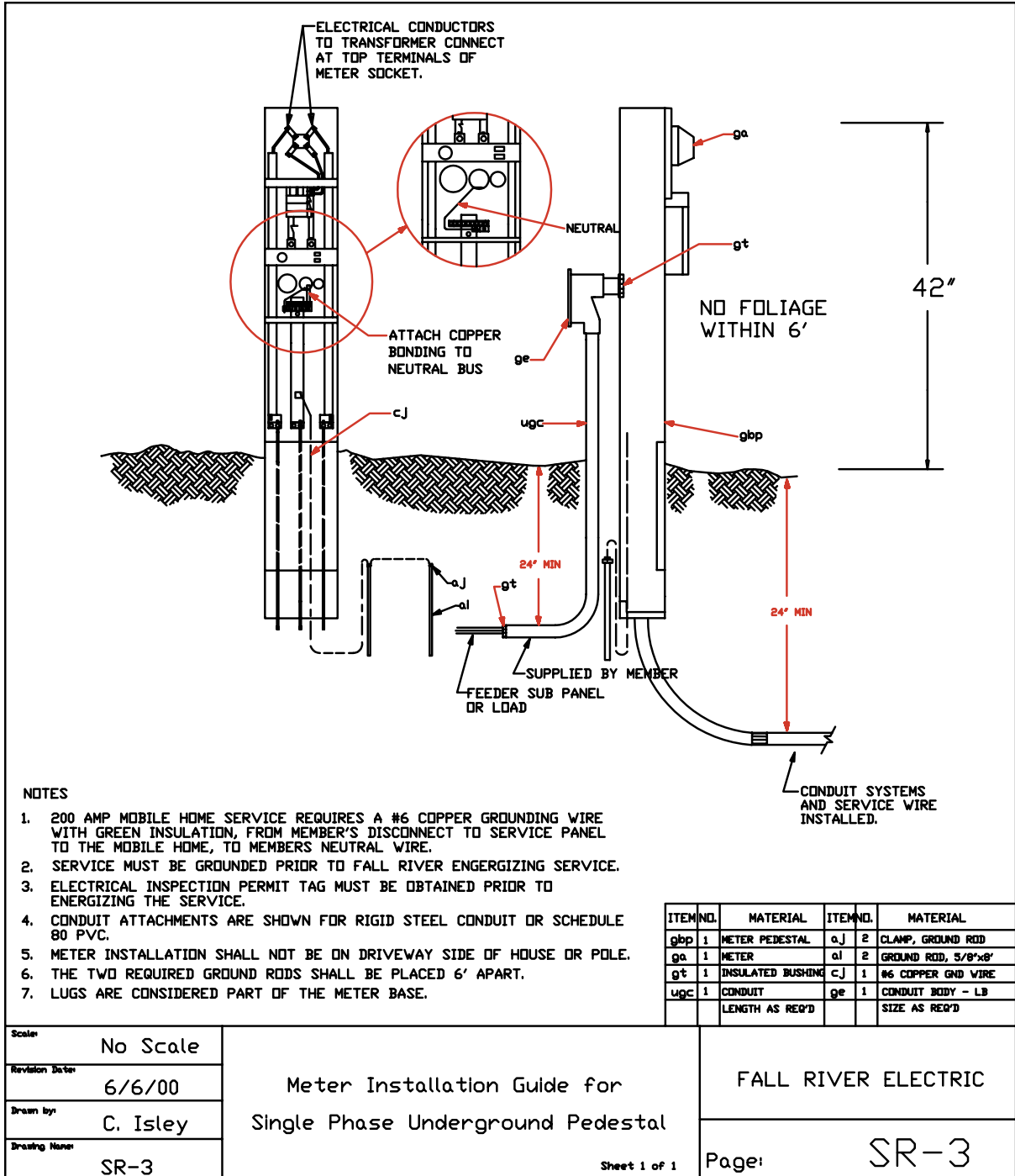

**NOTES**

1. 200 AMP MOBILE HOME SERVICE REQUIRES A #6 COPPER GROUNDING WIRE WITH GREEN INSULATION, FROM MEMBER'S DISCONNECT TO SERVICE PANEL TO THE MOBILE HOME, TO MEMBER'S NEUTRAL WIRE.
2. SERVICE MUST BE GROUNDED PRIOR TO FALL RIVER ENERGIZING SERVICE.
3. ELECTRICAL INSPECTION PERMIT TAG MUST BE OBTAINED PRIOR TO ENERGIZING THE SERVICE.
4. CONDUIT ATTACHMENTS ARE SHOWN FOR RIGID STEEL CONDUIT OR SCHEDULE 80 PVC.
5. METER INSTALLATION SHALL NOT BE ON DRIVEWAY SIDE OF HOUSE OR POLE.
6. THE TWO REQUIRED GROUND RODS SHALL BE PLACED 6' APART.
7. LUGS ARE CONSIDERED PART OF THE METER BASE.

ITEM NO.	MATERIAL	ITEM NO.	MATERIAL
gbp	1 METER PEDESTAL	aj	2 CLAMP, GROUND ROD
ga	1 METER	al	2 GROUND ROD, 5/8"x8'
gt	1 INSULATED BUSHING	cj	1 #6 COPPER GND WIRE
ugc	1 CONDUIT	ge	1 CONDUIT BODY - LB
	LENGTH AS REQ'D		SIZE AS REQ'D

Scale:	No Scale
Revision Date:	6/6/00
Drawn by:	C. Isley
Drawing Name:	SR-3

Meter Installation Guide for  
Single Phase Underground Pedestal

Sheet 1 of 1

FALL RIVER ELECTRIC
Page: SR-3

**SR-3. METER INSTALLATION GUIDE FOR SINGLE PHASE UNDERGROUND PEDESTAL**

# BARRIER POST

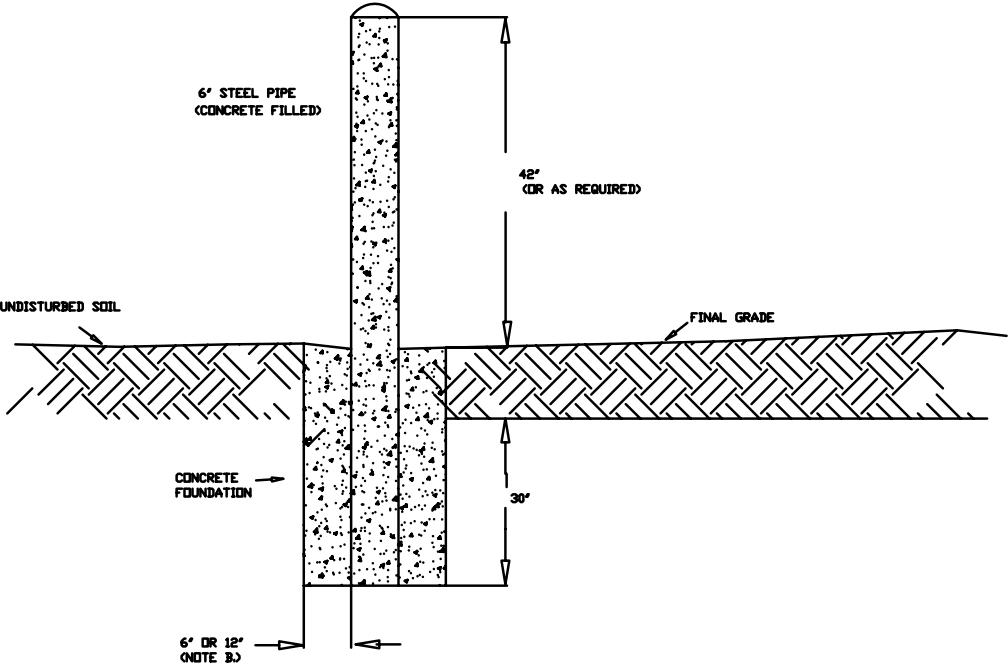

Scale:	No Scale	BARRIER POST	FALL RIVER ELECTRIC
Revision Date:	7/14/97		
Drawn by:	R. HATHAWAY		
Drawing Name:	SR-3A		Page: SR-3A
		Sheet 1 of 1	

SR-3A. BARRIER POST



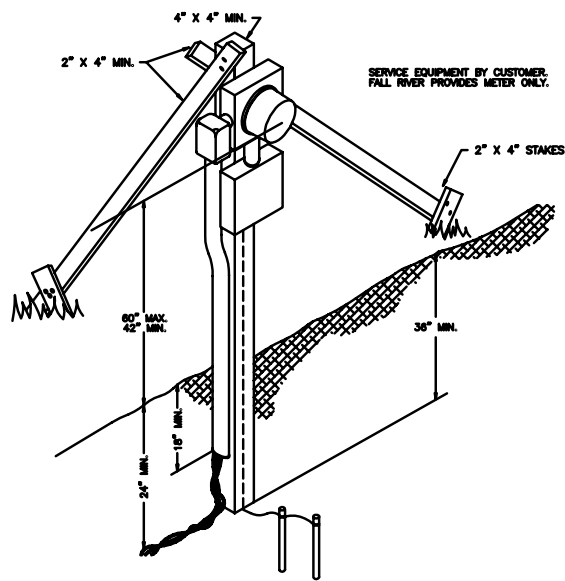

**NOTES:**

- 48 HOURS PRIOR TO DIGGING PHONE 1-800-342-1585 (IDAHO); 1-800-424-5555 (MONTANA)
- THE MEMBER SHALL PROVIDE ALL TRENCH AND BACKFILL TO WITHIN 3' OF TRANSFORMER. CONTACT A FALL RIVER REPRESENTATIVE PRIOR TO TRENCHING, FOR COORDINATION.
- TEMPORARY SERVICE ARRANGEMENT AND EQUIPMENT TO BE "APPROVED FOR SERVICE" BY THE STATE ELECTRICAL INSPECTOR BEFORE FALL RIVER WILL CONNECT SERVICE.
- THE MEMBER SHALL NOTIFY FALL RIVER A MINIMUM OF 2 WEEKS PRIOR TO WHEN SERVICE IS REQUIRED.
- TEMPORARY POWER CONNECTIONS SHALL NOT BE MADE THROUGH PERMANENT SERVICE STUB-OUTS.
- DETAILS SHOWN HEREON REFLECT MINIMUM ELECTRIC REQUIREMENTS AND ARE NOT INTENDED TO DEPICT STATE ELECTRIC REQUIREMENTS.

Scale	No Scale	TEMPORARY SERVICE REQUIREMENTS FOR UNDERGROUND SERVICE	FALL RIVER ELECTRIC
Revision Date	6/00		
Drawn by	C. Isley REVISED BY: LB		
Drawing Name	SR-5	Sheet 1 of 1	Page: SR-5

**SR-5. TEMPORARY SERVICE REQUIREMENTS FOR UNDERGROUND SERVICE**

# SERVICE REQUIREMENT DRAWINGS

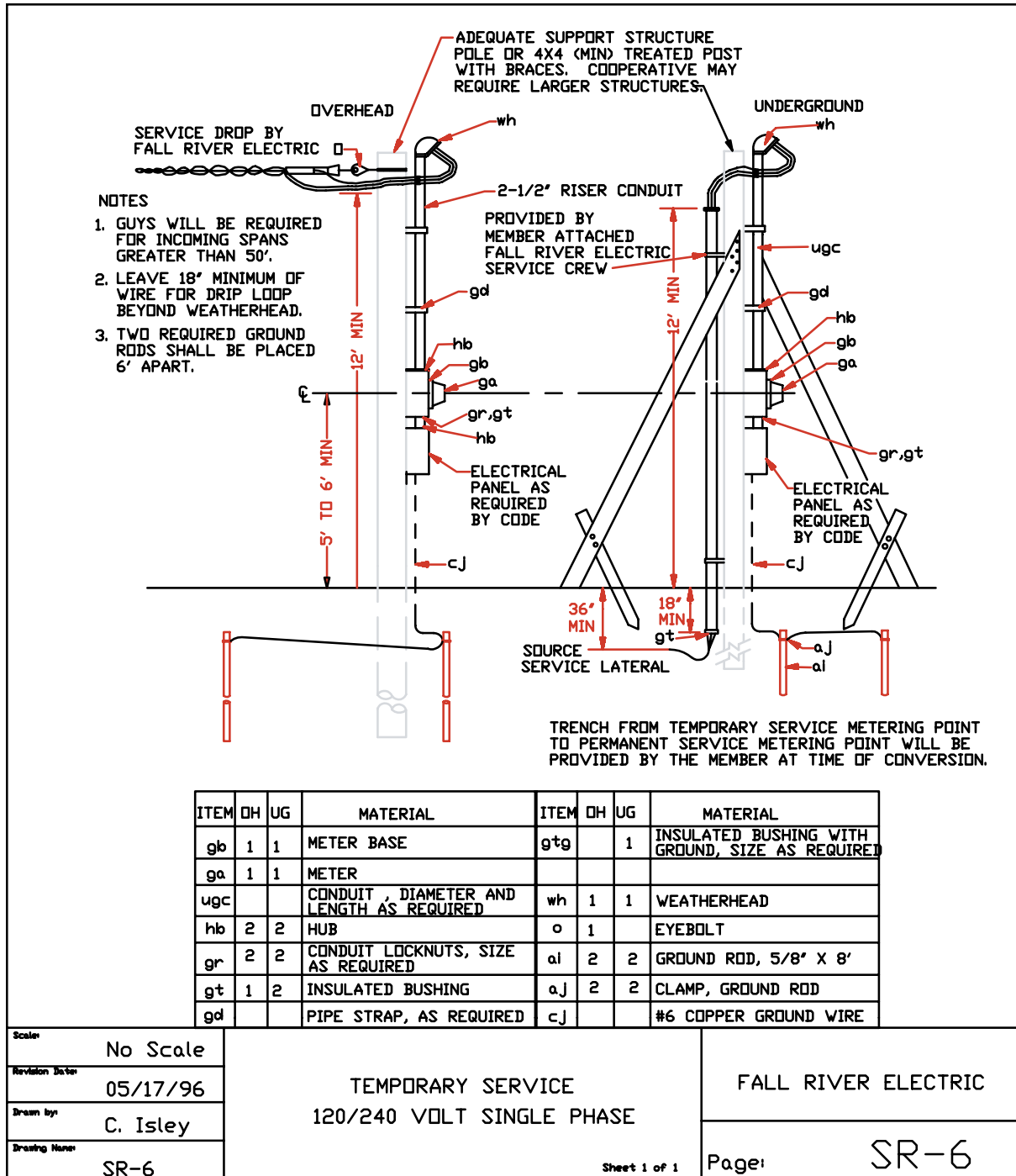

**SR-6. TEMPORARY SERVICE 120/240 VOLT SINGLE PHASE**



SERVICE DETAIL  
SINGLE-FAMILY DWELLING

MEMBER-SUPPLIED TRENCH AND CONDUIT FOR UNDERGROUND SERVICE

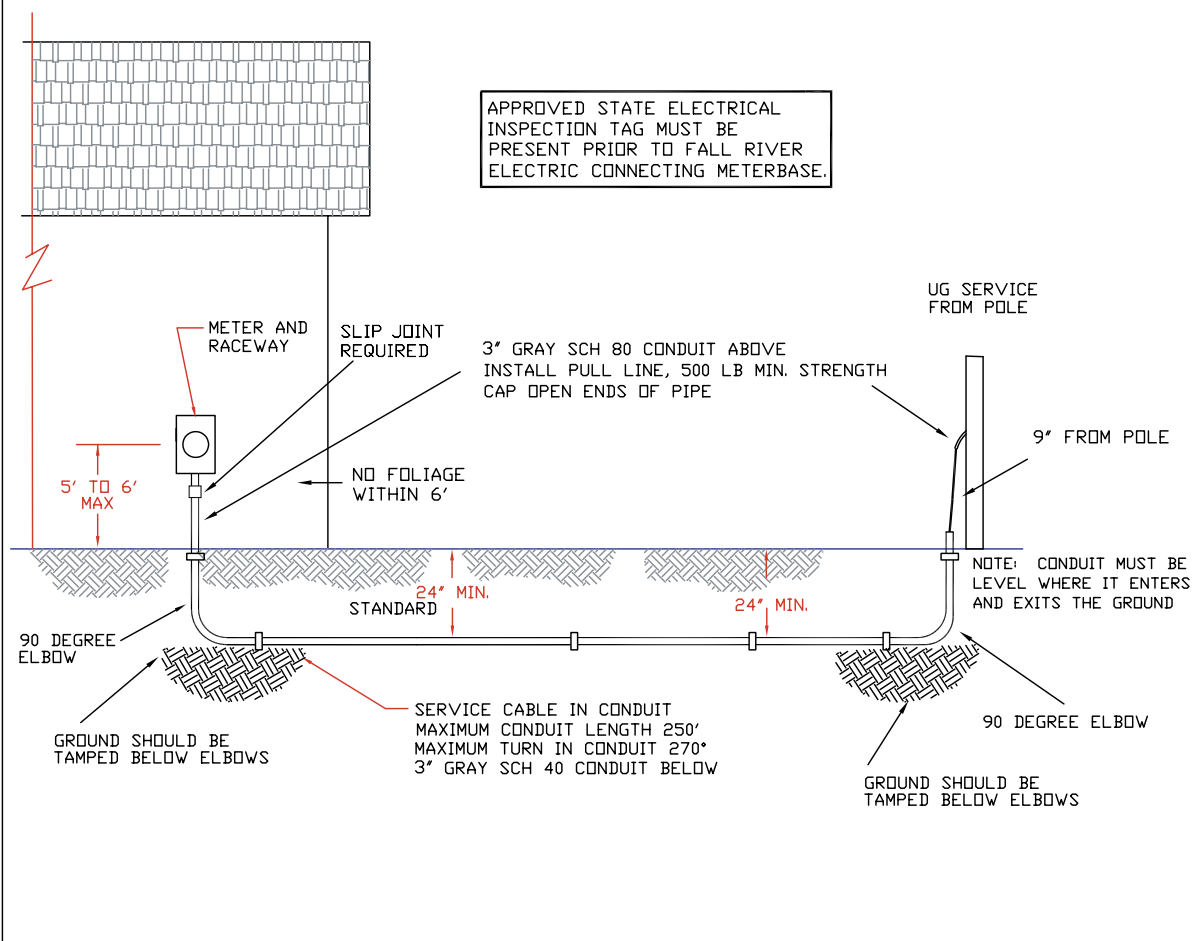

Scale:	No Scale	UNDERGROUND SERVICE FROM OVERHEAD POLE & TRANSFORMER TO HOUSE	FALL RIVER ELECTRIC
Revision Date:	3/07		
Drawn by:	C. Isley		Page: SR-7B
Drawing Name:	SR-7		

Sheet 1 of 1

**SR-7B. UNDERGROUND SERVICE FROM OVERHEAD POLE & TRANSFORMER TO HOUSE**

# SERVICE REQUIREMENT DRAWINGS

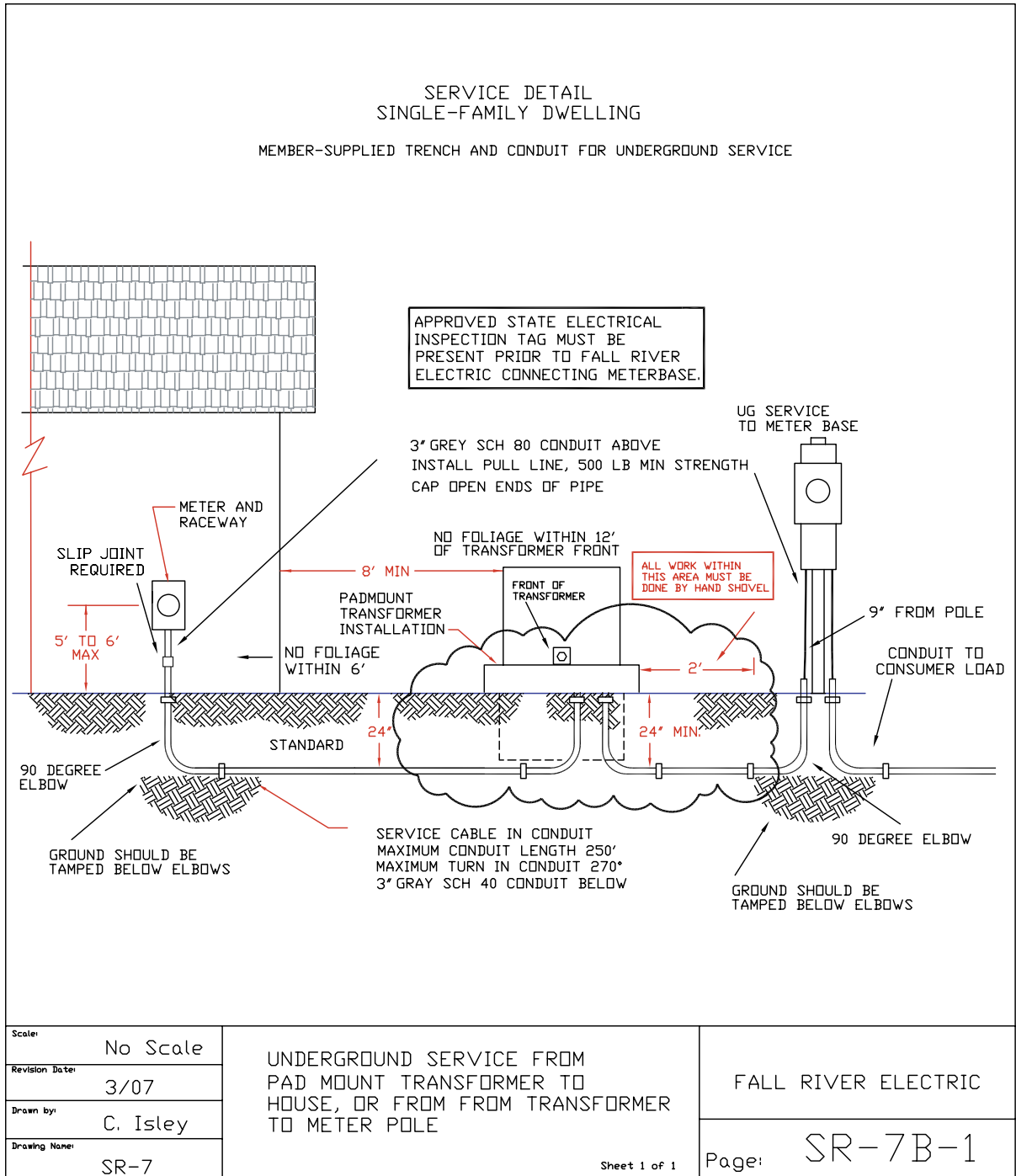

**SR-7B-1. UNDERGROUND SERVICE FROM PAD MOUNT TRANSFORMER TO HOUSE, OR FROM TRANSFORMER TO METER POLE**

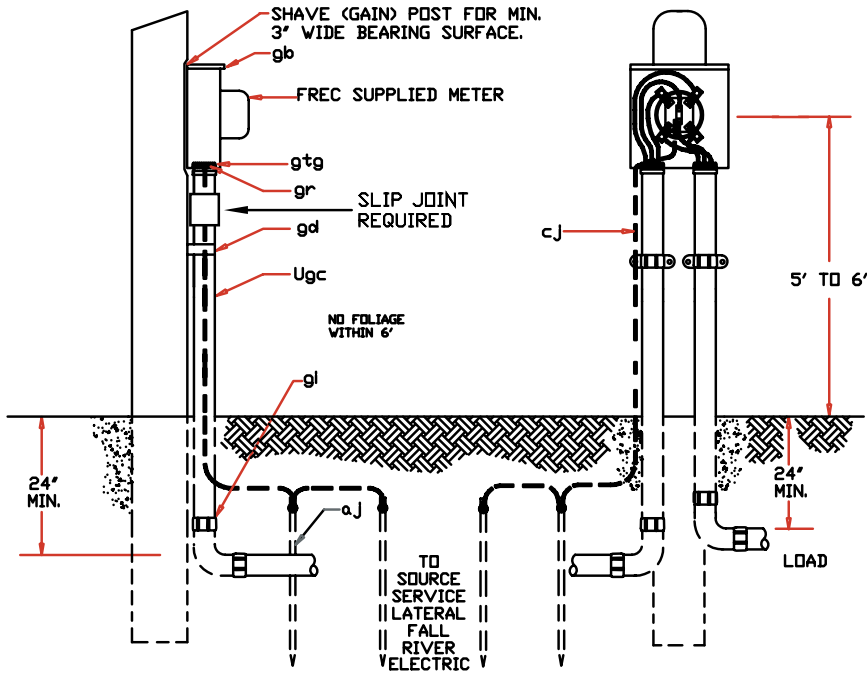

NOTE :

1. SERVICE MUST BE GROUNDED PRIOR TO FALL RIVER ENERGIZING SERVICE.
2. ELECTRICAL INSPECTION PERMIT TAG MUST BE OBTAINED PRIOR TO ENERGIZING THE SERVICE.
3. CONDUIT ATTACHMENTS ARE SHOWN FOR STEEL CONDUIT.
4. METER INSTALLATION SHALL NOT BE ON DRIVEWAY SIDE OF HOUSE OR POLE.
5. 3' CONDUIT FOR 200 AMP SERVICE.
6. 4' CONDUIT FOR 400 AMP SERVICE.
7. THE TWO REQUIRED GROUND RODS SHALL BE PLACED 6' APART.
8. SEE THE ITEMS MARKED "\*" BELOW TO BE PROVIDED BY THE MEMBER.

CONTACT FALL RIVER FOR CONDUIT SIZE

ITEM NO.	MEMBER SUPPLIED MATERIAL
1	WOOD POST - TREATED.
gb	METER BASE
Ugc	CONDUIT, 2" MIN. (OR AS REQ'D BY CODE) DIA., GRS. OR SCHEDULE 80 PVC AND INC.
Ugc	90° CONDUIT SWEEP, SIZED TO NEC CODE REQUIREMENTS.
gr	CONDUIT LOCKNUTS, SIZE AS REQUIRED
gl	CONDUIT COUPLING
gtg	INSULATED BUSHING WITH GROUND, SIZE AS REQUIRED.
gd	PIPE STRAPS
oJ	GROUND ROD, 5/8" x 8', WITH CLAMP
cJ	#6 COPPER, GROUND WIRE

Scale	No Scale	METER PEDESTAL WOOD POST	FALL RIVER ELECTRIC
Revision Date	03/25/96		
Drawn by	C. Isley		Page: SR-8
Drawing Name	SR-8		

Sheet 1 of 1

SR-8. METER PEDESTAL WOOD POST

# SERVICE REQUIREMENT DRAWINGS

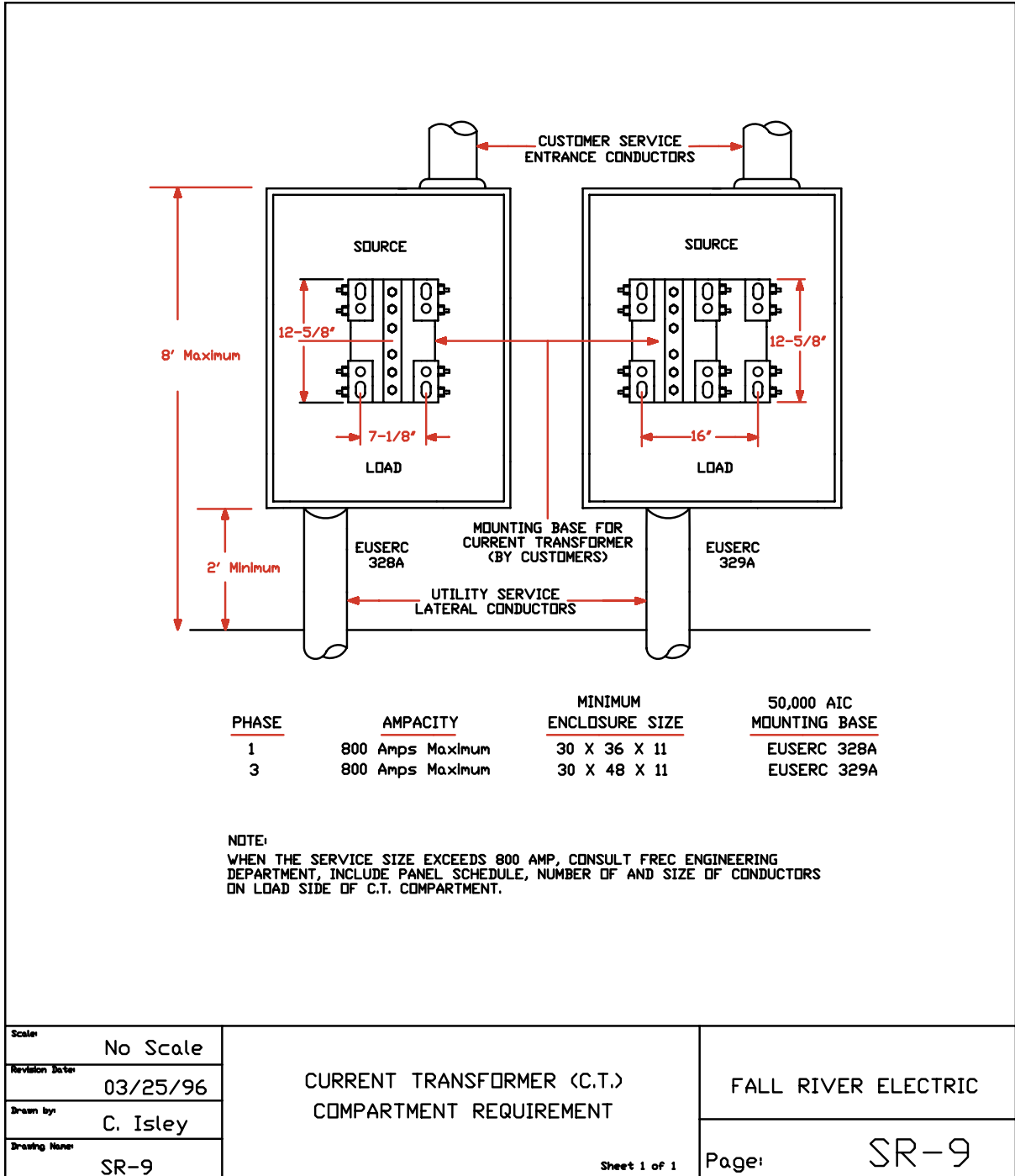

**SR-9. CURRENT TRANSFORMER (C.T.) COMPARTMENT REQUIREMENT**

NOTES: (CONSULT FALL RIVER ELECTRIC REGARDING ANY EXCEPTIONS TO THESE REQUIREMENTS.)

1. CONSULT FALL RIVER ELECTRIC FOR AVAILABLE FAULT CURRENT BEFORE PURCHASING ELECTRIC SERVICE EQUIPMENT.
2. CABINET COVERS SHALL BE LOCKABLE.
3. CABINETS SHALL BE RAIN-TIGHT.
4. CABINETS OF 30 X 48 X 11, OR LARGER, SHALL BE HINGED COVER.
5. FALL RIVER ELECTRIC WILL PROVIDE CTs.
6. MEMBER SHALL PROVIDE AND INSTALL CABINET ENCLOSURE AND CT MOUNTING BRACE, WITH LINE AND LOAD CONNECTORS.
7. THE MAXIMUM NUMBER OF LOAD CONDUCTORS PER PHASE INTO THE CT, ITSELF, IS LIMITED TO TWO (2) WITHOUT FALL RIVER ENGINEERING APPROVAL.
8. FALL RIVER ELECTRIC WILL INSTALL AND MAKE UP THE LINE SIDE CONNECTIONS. CHECK WITH FALL RIVER REGARDING THE LOAD SIDE CONNECTIONS.
9. CHECK WITH FALL RIVER ELECTRIC FOR ALTERNATE CONDUIT LOCATIONS.
10. ONLY CONDUCTORS ASSOCIATED WITH METERING OR GROUNDING SHALL BE PERMITTED IN THE CURRENT TRANSFORMER ENCLOSURE. NO CONNECTIONS SHALL BE MADE IN ANY CURRENT TRANSFORMER ENCLOSURE TO SUPPLY ANY OTHER METER.
11. CONSULT WITH FALL RIVER ELECTRIC'S ENGINEERING DEPARTMENT ON CT COMPARTMENT LOCATION. IF POSSIBLE, METER BASE SHALL BE LOCATED WITHIN TWO (2) FEET OF CT COMPARTMENT. NO CONDUITS OR JUNCTIONS ARE ALLOWED IN METER CONDUCTOR CONDUIT, AND NOT MORE THAN 270 DEGREES IN BENDS WILL BE ALLOWED.
12. WHERE CURRENT TRANSFORMERS OR OTHER EQUIPMENT IS INSTALLED IN A LOCATION WHERE IT MIGHT BE STRUCK BY A MOTORIZED VEHICLE, THE CUSTOMER IS TO INSTALL AND MAINTAIN FALL RIVER ELECTRIC APPROVED BARRIER POSTS TO PROTECT THE EQUIPMENT.
13. MEMBER WILL INSTALL FUSE OR BREAKERS ON ALL LATERALS EXCEEDING 50' FROM ALL METERS AND CURRENT TRANSFORMER CABINETS AND/OR CHECK WITH FALL RIVER ELECTRIC'S ENGINEERING DEPARTMENT.

Scale:	No Scale	CURRENT TRANSFORMER (C.T.) COMPARTMENT REQUIREMENT	FALL RIVER ELECTRIC
Revision Date:	04/02/96		
Drawn by:	C. Isley		
Drawing Name:	SR-10		Page: SR-10
		Sheet 1 of 1	

**SR-10. CURRENT TRANSFORMER (C.T.) COMPARTMENT REQUIREMENT**

# SERVICE REQUIREMENT DRAWINGS

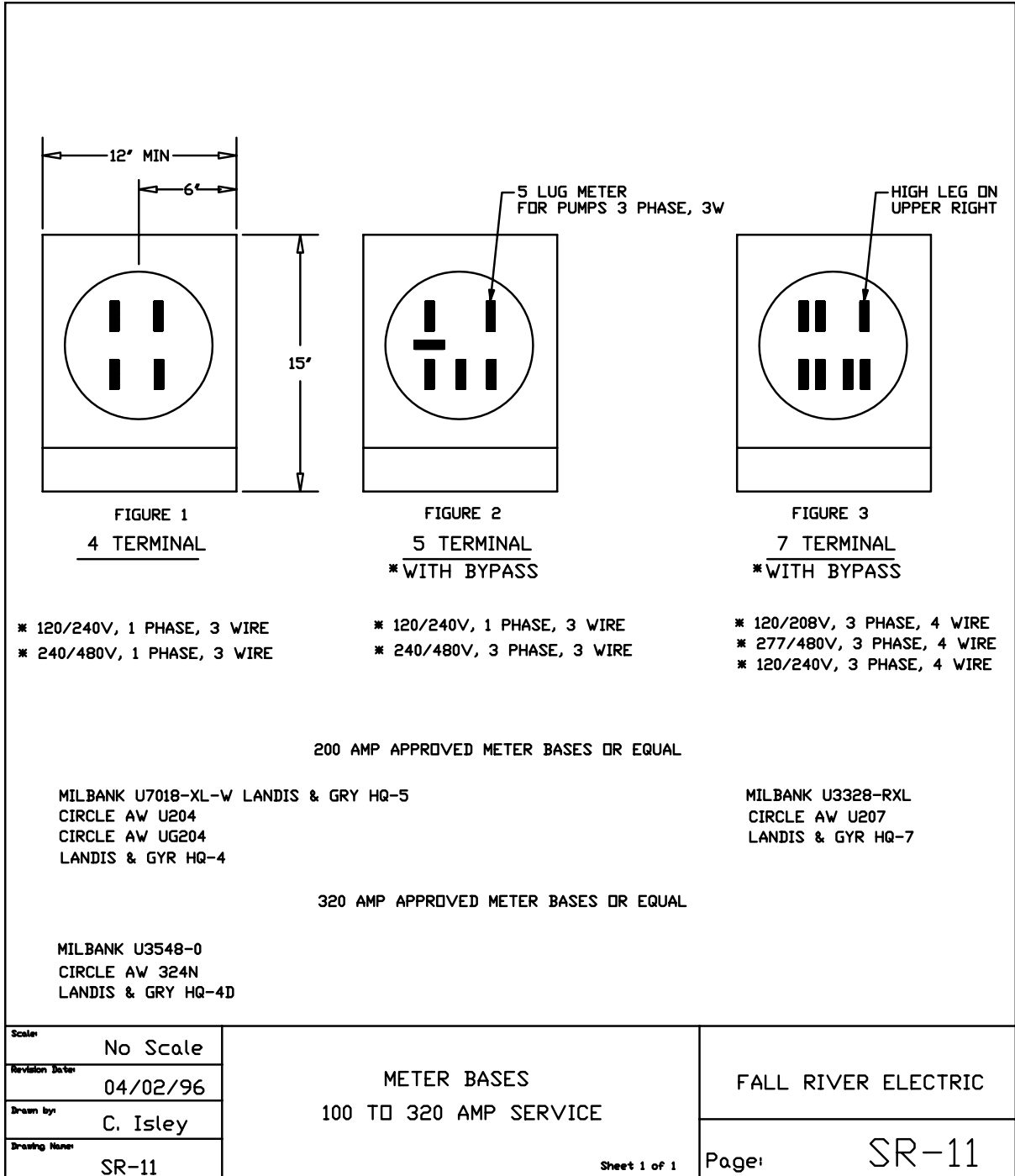

**SR-11. METER BASES 100 TO 320 SERVICE**

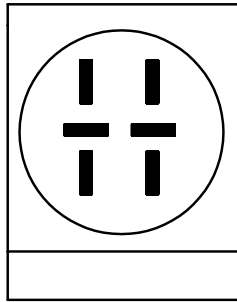

6 TERMINAL  
CURRENT TRANSFORMER  
WITH BYPASS

\* 120/240V, 1 PHASE, 3 WIRE

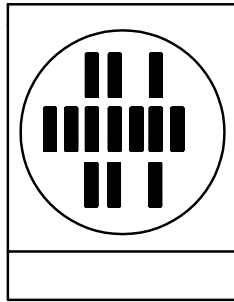

13 TERMINAL  
CURRENT TRANSFORMER  
WITH BYPASS

\* 120/208V, 3 PHASE, 4 WIRE  
\* 277/480V, 3 PHASE, 4 WIRE  
\* 120/240V, 3 PHASE, 4 WIRE

APPROVED METER BASES OR EQUAL

MILBANK UC3436-XL  
CIRCLE AW 12146  
LANDIS & GRY HQ-6TS

MILBANK UC3433-XL  
CIRCLE AW 121413  
LANDIS & GYR HQ-13TS

NOTES:

1. FALL RIVER ELECTRIC WILL PROVIDE METER BASE, CURRENT TRANSFORMERS, AND WIRE CURRENT TRANSFORMER INSTALLATIONS.

Scale	No Scale	METER BASES FOR CURRENT TRANSFORMER INSTALLATIONS	FALL RIVER ELECTRIC
Revision Date	04/02/96		
Drawn by	C. Isley		
Drawing Name	SR-12		Page: SR-12
		Sheet 1 of 1	

**SR-12. METER BASES FOR CURRENT TRANSFORMER INSTALLATIONS**

# SERVICE REQUIREMENT DRAWINGS

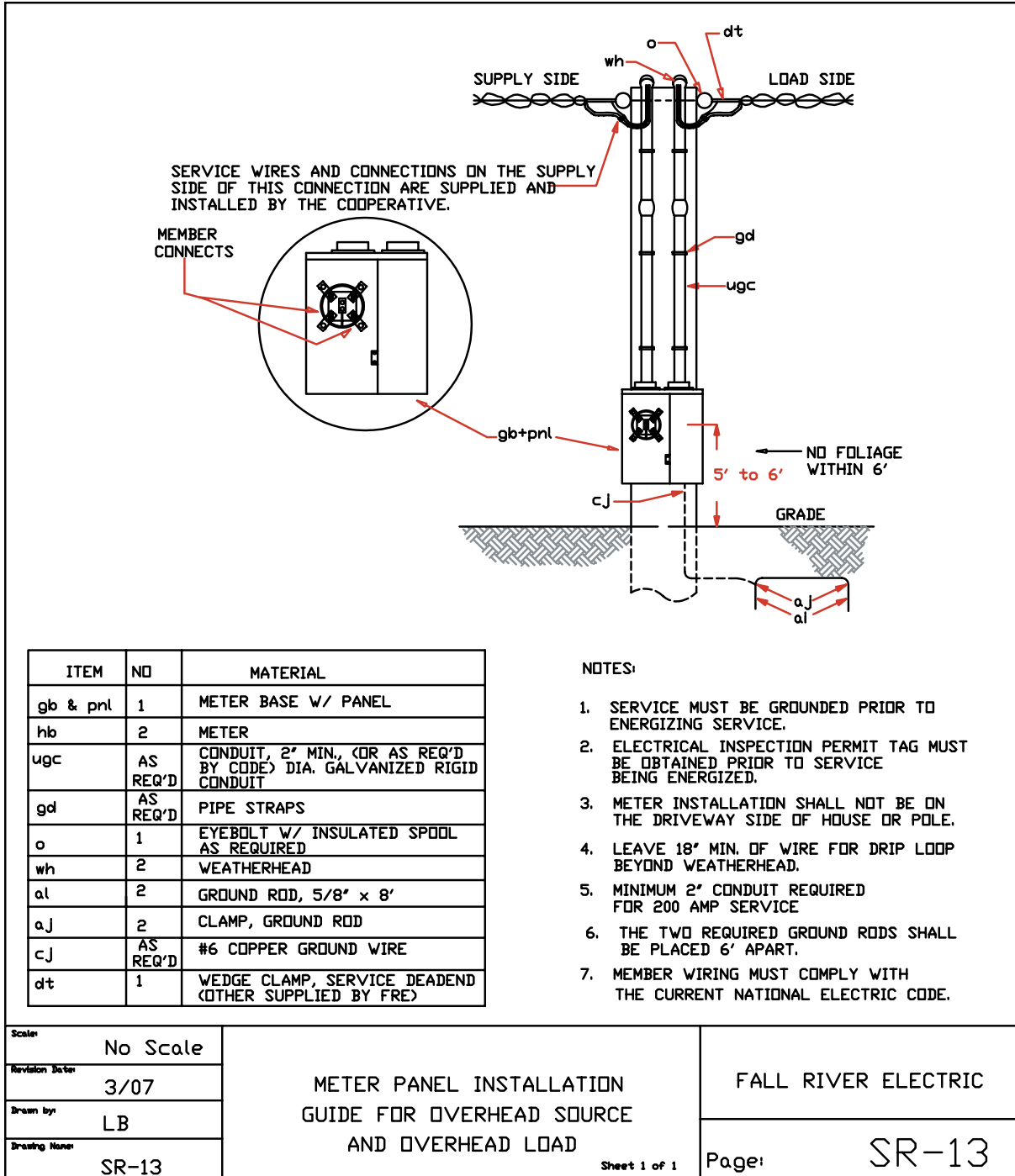

SR-13. METER WITH PANEL INSTALLATION GUIDE FOR OVERHEAD SOURCE AND OVERHEAD LOAD



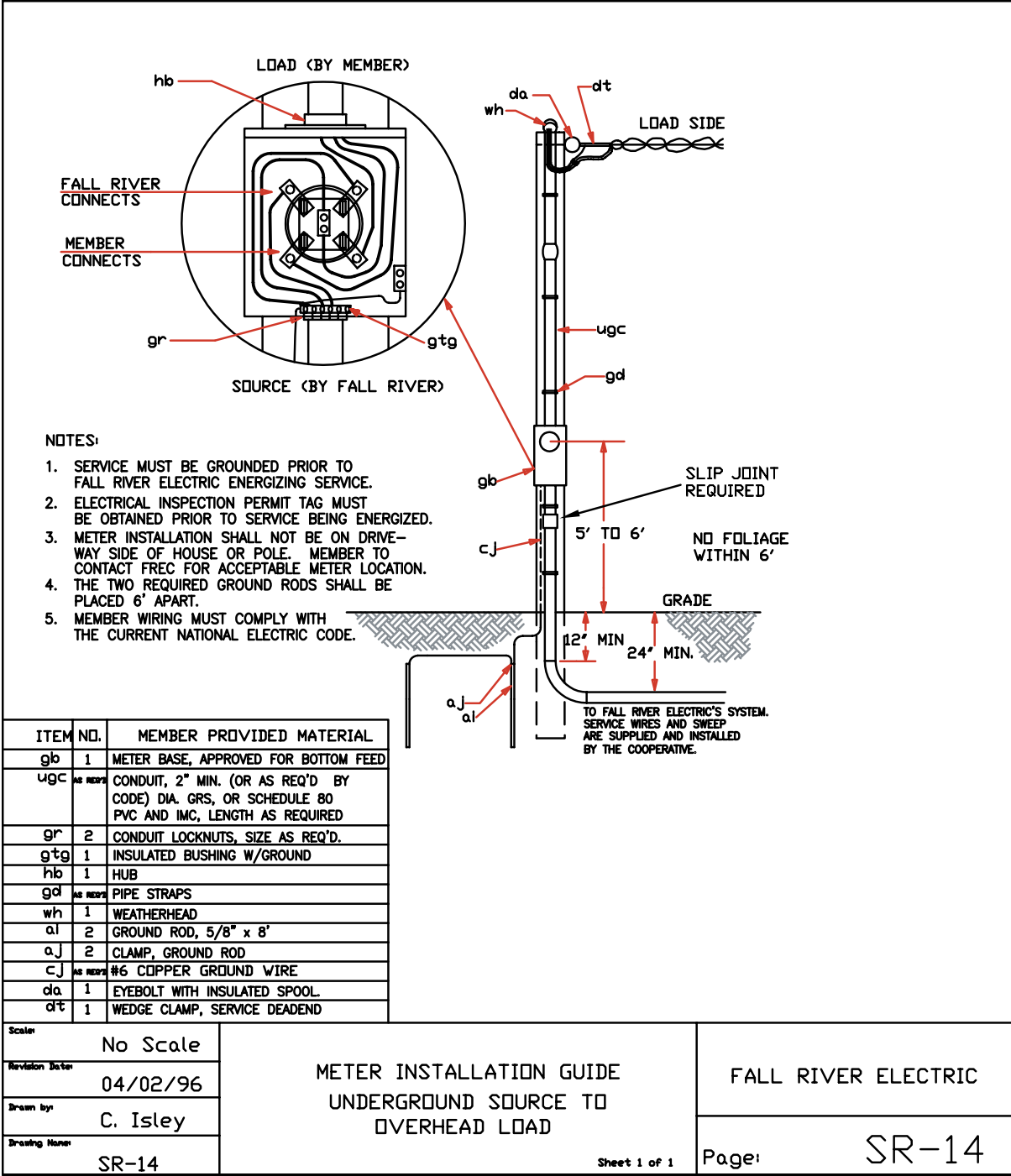

**SR-14. METER INSTALLATION GUIDE UNDERGROUND SOURCE TO OVERHEAD LOAD**

# SERVICE REQUIREMENT DRAWINGS

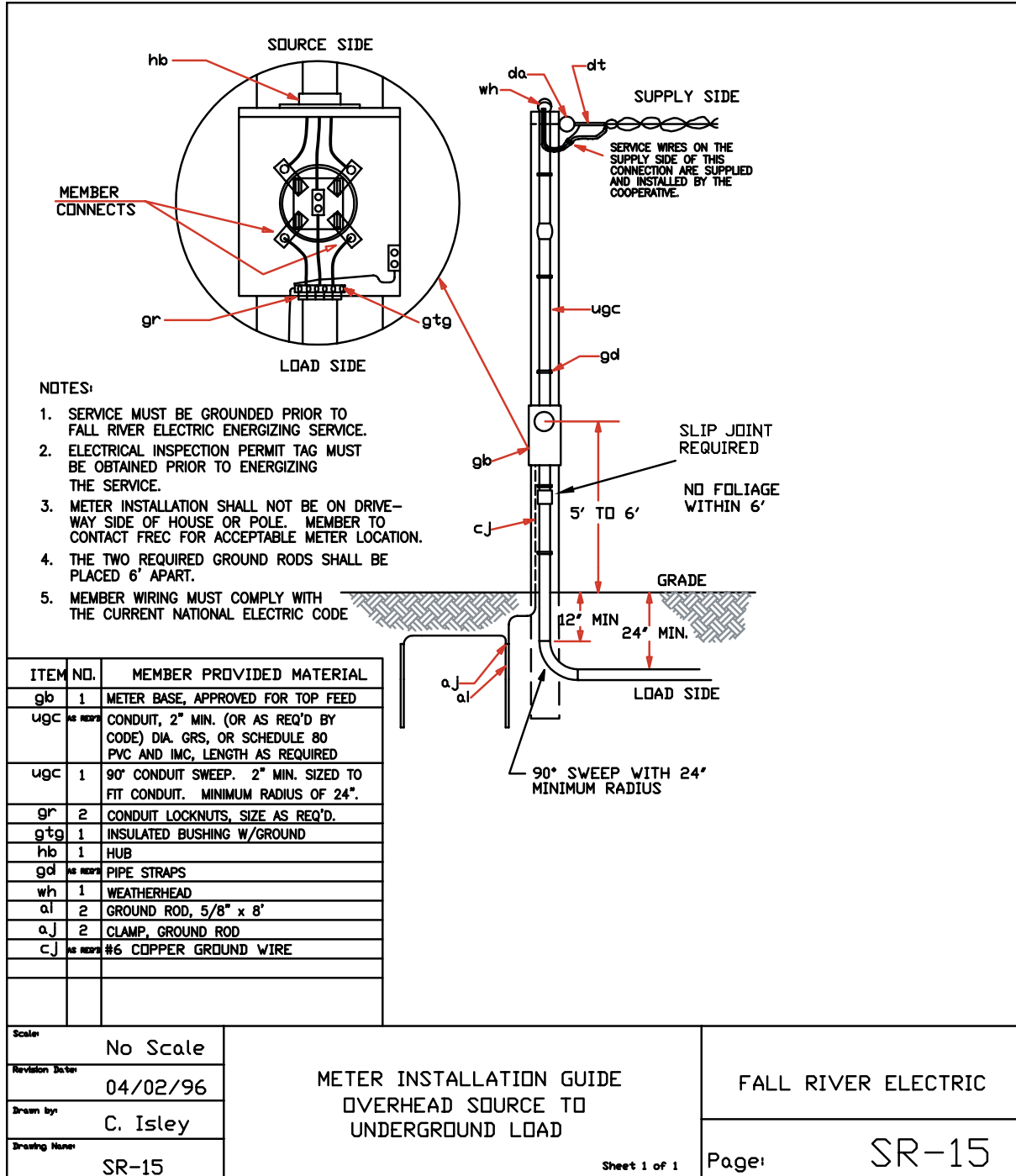

**SR-15. METER INSTALLATION GUIDE OVERHEAD SOURCE TO UNDERGROUND LOAD**

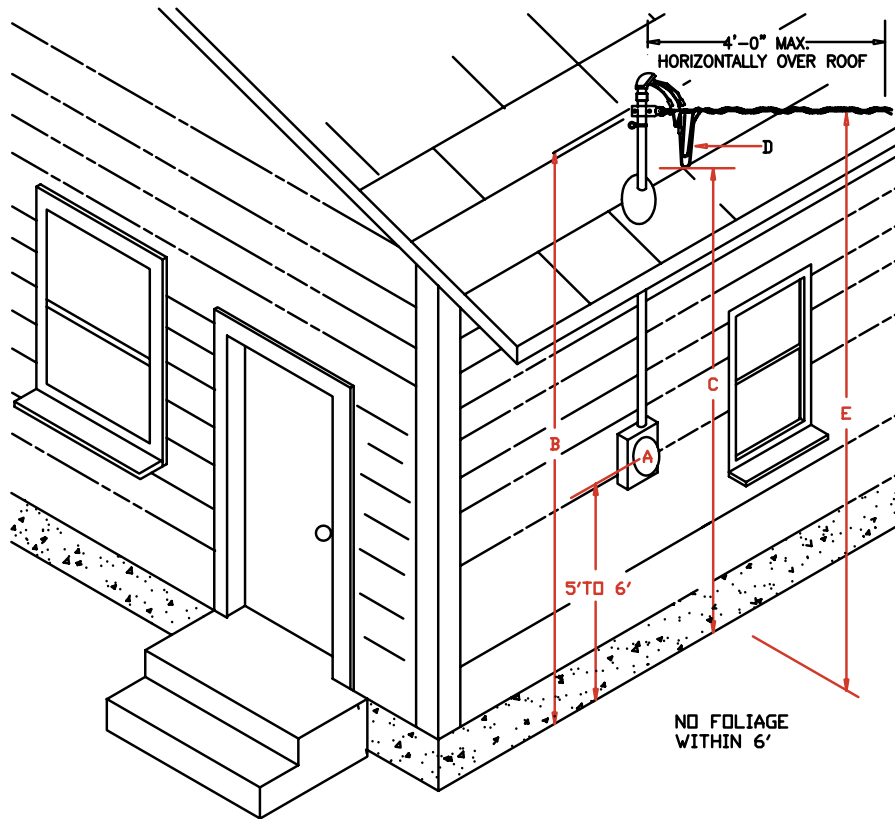

- A. METER LOCATION MUST BE APPROVED BY FALL RIVER PRIOR TO INSTALLATION. SEE ARTICLE 2.03.
- B. POINT OF ATTACHMENT 12 FEET MINIMUM ABOVE FINISHED GRADE, OR FROM ANY PLATFORM OR PROJECTION FROM WHICH CONDUCTORS MAY BE REACHED.
- C. THE OPEN CONDUCTORS OF THE SERVICE ENTRANCE MUST BE A MINIMUM OF 10 FEET ABOVE FINISHED GRADE, OR FROM ANY PLATFORM OR PROJECTION FROM WHICH THEY MAY BE REACHED.
- D. THE CABLE AND DRIP LOOP MUST BE AT LEAST 18 INCHES ABOVE THE ROOF.
- E. 12 FOOT ABOVE FINISHED GRADE AND OVER RESIDENTIAL DRIVEWAYS, 18 FOOT OVER STREETS, AND AREAS SUBJECT TO TRUCK TRAFFIC.

NOTE: CLEARANCES B,C,D AND E ARE BASED ON THE CURRENT NATIONAL ELECTRIC CODE AND ARE APPLIED WHERE THE VOLTAGE IS LIMITED TO 150 VOLTS TO GROUND.

Scale	No Scale	TYPICAL RESIDENTIAL OVERHEAD SERVICE	FALL RIVER ELECTRIC
Revision Date	04/02/96		
Drawn by	C. Isley		
Drawing Name	SR-16		Page: SR-16
		Sheet 1 of 1	

**SR-16. TYPICAL RESIDENTIAL OVERHEAD SERVICE**

# SERVICE REQUIREMENT DRAWINGS

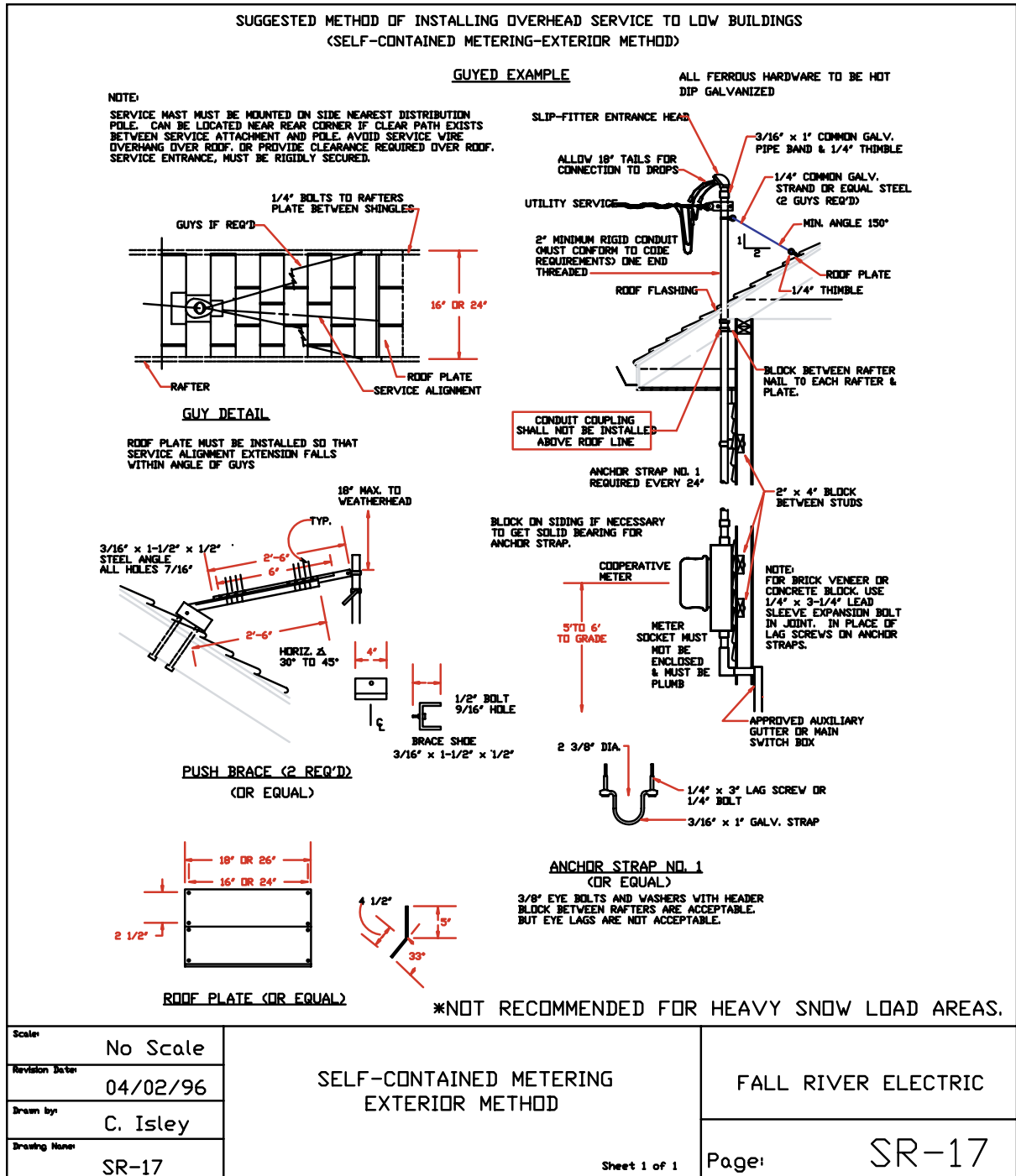

**SR-17. SELF-CONTAINED METERING EXTERIOR METHOD**

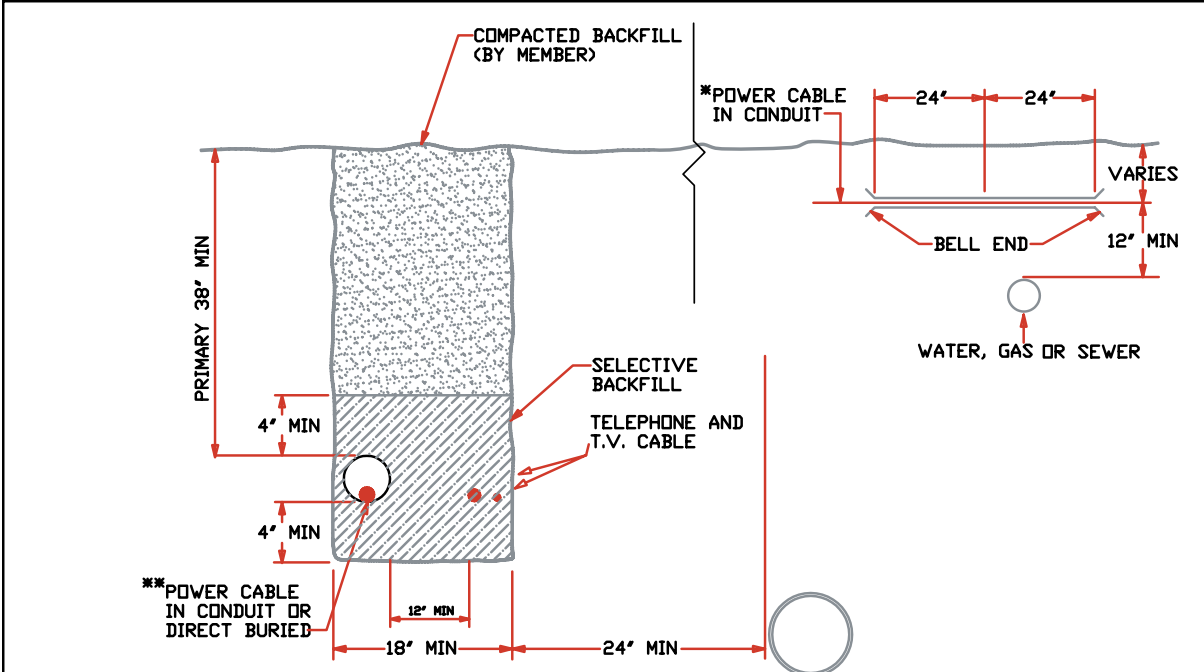

NOTE: ALL TRENCHES ARE TO BE INSPECTED PRIOR TO BACKFILLING.

\* WHEN ELECTRICAL CONDUCTORS CROSS OVER OR UNDER WATER AND/OR GAS PIPES THERE SHALL BE A MINIMUM OF 12 INCHES VERTICAL SEPARATION. IN ADDITION, THE ELECTRICAL CONDUCTORS SHALL BE PROTECTED WITH NOT LESS THAN 24" OF SUITABLE PVC OR RIGID STEEL CONDUIT ON EITHER SIDE OF THE CROSSING.

\*\*CABLE MINIMUM DEPTH  
ACCEPTABLE PRIMARY CABLE DEPTHS:  
30" MINIMUM CONDUIT DEPTH  
38" MINIMUM OR MORE FOR DIRECT BURIAL DEPTH

CONDUIT REQUIRED IN DEVELOPED OR LANDSCAPED AREA.

JOINT USE TRENCHES--CONTACT FALL RIVER ENGINEERING DEPARTMENT.

\* MEMBER INSTALLED CONDUIT MUST BE INSPECTED BY THE STATE OF IDAHO IF DEPTH REQUIREMENTS ARE NOT POSSIBLE, PLEASE CONTACT FALL RIVER ELECTRIC'S ENGINEERING DEPARTMENT FOR ALTERNATIVES.

Scale	No Scale	PRIMARY UNDERGROUND TRENCH AND CONDUIT REQUIREMENTS	FALL RIVER ELECTRIC
Revision Date	3/07		
Drawn by	C. Isley		
Drawing Name	SR-18		Page: SR-18

SR-18. UNDERGROUND TRENCH AND CONDUIT REQUIREMENTS

# SERVICE REQUIREMENT DRAWINGS

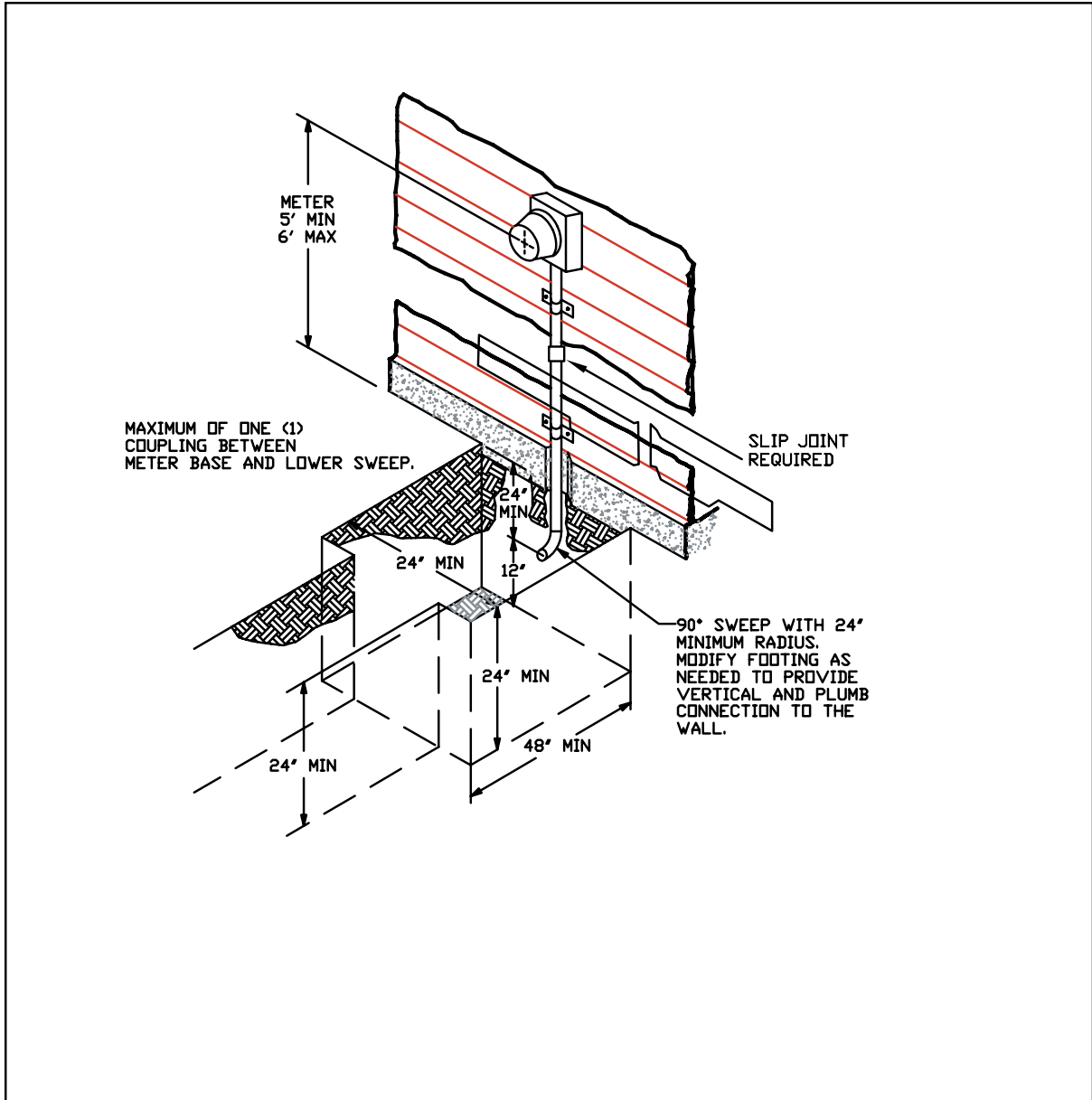

Scale:	No Scale	RESIDENTIAL SERVICE ENTRANCE WORKING SPACE (PROVIDED BY MEMBER)	FALL RIVER ELECTRIC
Revision Date:	3/07		
Drawn by:	C. Isley		
Drawing Name:	SR-19		Sheet 1 of 1

**SR-19. RESIDENTIAL SERVICE ENTRANCE WORKING SPACE (PROVIDED BY MEMBER)**

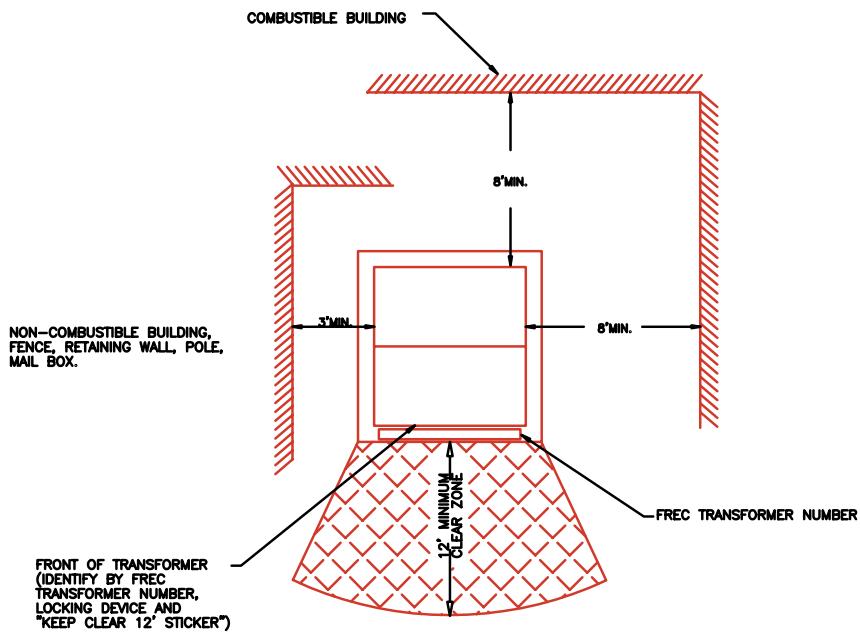

**NOTES:**  
 - NO OBSTRUCTIONS ALLOWED OVER TRANSFORMER

Scale	No Scale	TYPICAL MINIMUM TRANSFORMER CLEARANCE REQUIREMENTS RESIDENTIAL	FALL RIVER ELECTRIC
Revision Date	05/17/97		Page: SR-20
Drawn by	C. Isley		
Drawing Name	SR-20		
		Sheet 1 of 1	

**SR-20. TYPICAL MINIMUM TRANSFORMER CLEARANCE REQUIREMENTS RESIDENTIAL**

# SERVICE REQUIREMENT DRAWINGS

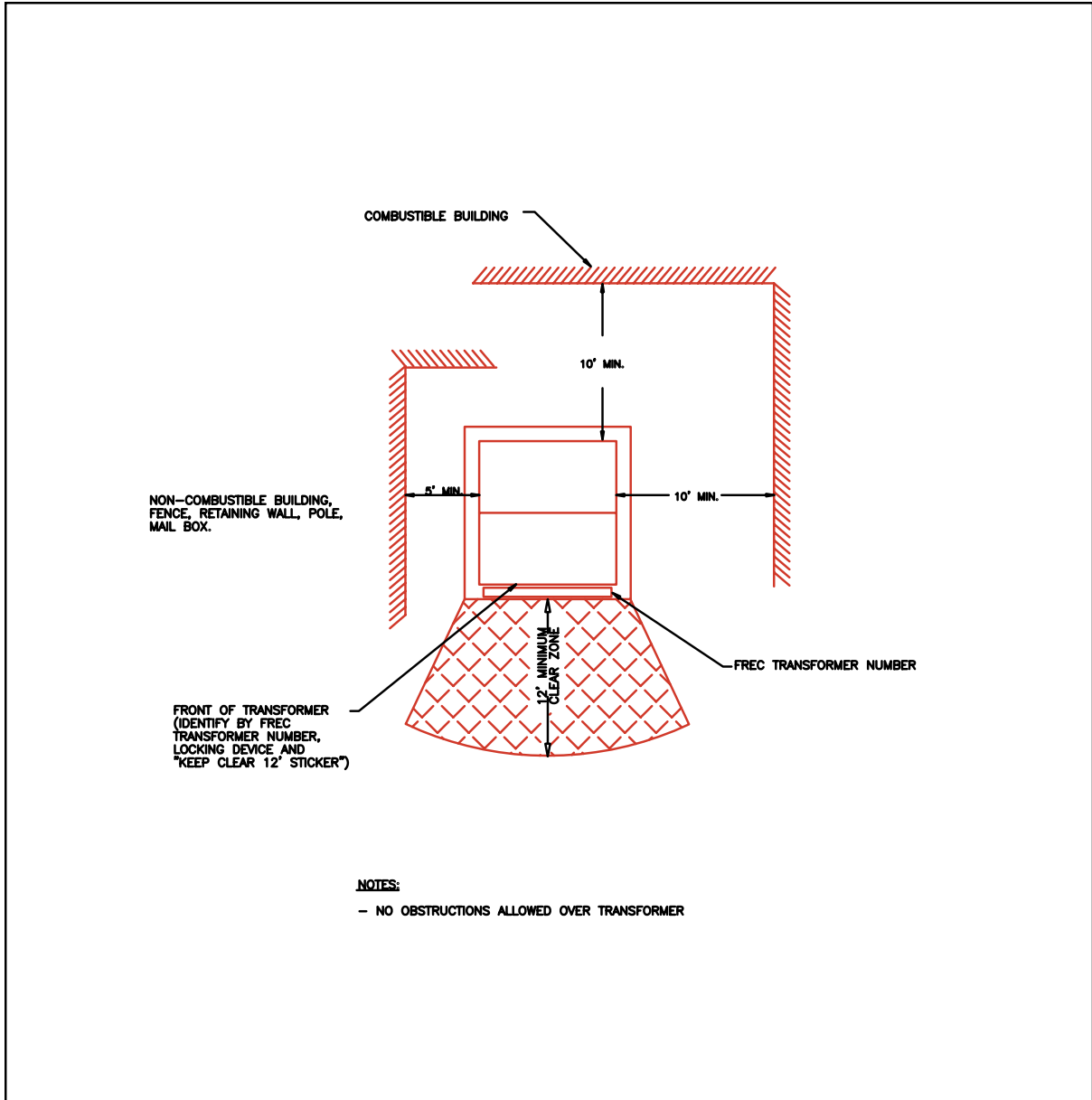

Scale:	No Scale	TYPICAL MINIMUM TRANSFORMER CLEARANCE REQUIREMENTS COMMERCIAL	FALL RIVER ELECTRIC YOUR ENERGY PARTNER
Revision Date:	05/17/97		
Drawn by:	C. Isley		Page: SR-21
Drawing Name:	SR-21		

Sheet 1 of 1

**SR-21. TYPICAL MINIMUM TRANSFORMER CLEARANCE REQUIREMENTS COMMERCIAL**



# GLOSSARY

**AID TO CONSTRUCTION:** A non-refundable sum of money that the member may be required to pay towards the construction of electrical facilities.

**AMPACITY:** The current-carrying capacity, expressed in amperes, of an electric conductor under stated thermal conditions.

**AMPERES:** A unit of current.

**BARRIER POST:** A post or structure strategically placed to physically protect electrical equipment from vehicular or other impact.

**CABINETS:** An enclosure designed from either surface or flush mounting, and provided with a frame on which hinged doors are fastened.

**CONDUCTOR/CABLE:** A wire or combination of wires not installed from one another, suitable for carrying an electric current. The conductor, depending upon application, may be bare or insulated.

**CONDUIT:** A hollow tube or duct used to house and protect electrical conductors. Note: Conduit may be designated as steel-pipe conduit, or Schedule 40 or 80 grey electrical PVC. If it contains only one tube or duct, it is called single-duct; if it contains more than one tube or duct, it is called multiple-duct, usually with the number of tubes or ducts as prefix, for example, two-duct multiple conduit.

**CURRENT TRANSFORMER CABINET:** A specially designed cabinet to enclose current transformers.

**CURRENT TRANSFORMER:** A device utilized to connect measuring instruments to either high voltage or high current conductors.

**DISCONNECT:** To disengage electric energy.

**DISTRIBUTION PANEL:** Also distribution center is the equipment wherein protective devices are located to protect low voltage and branch circuits.

**EASEMENTS:** A legal right or privilege a person or entity may have to access and to utilize for specific purposes another's property.

**ENCLOSURE:** A containment or structure designed to protect equipment and minimize the possibility, under normal conditions, of dangerous approach or accidental contact with equipment by persons or objects.

**EUSERC:** An acronym referring to the Electric Utility Service Equipment Requirements Committee that promotes uniform electric service requirements among utilities.

**FAULT CURRENT:** The minimum current that will be available if one energized contacts another energized conductor or to ground.

**GANGED METER INSTALLATION:** An installation wherein more than one electric meter is installed and is connected to a single energy supply from the utility.

**GRADE, INITIAL:** The existing elevation of the earth or a structure before starting any construction activity.

**GRADE, FINISHED:** The final elevation upon completion of the construction.

**GUTTERS:** A type of enclosure that is normally used for physically interconnecting cabinets (must be sealable).

**METER SOCKET:** The portion of the member's service entrance equipment that is designed to contain the electrical meter.

**METERED LOAD:** Any energy consumption that is metered and/or recorded.

**PAD-MOUNTED TRANSFORMER:** A general term describing enclosed transformers, which are installed at ground

# GLOSSARY (continued)

level and positioned at final grade.

**PEDESTAL:** An enclosure wherein the connection of underground conductors can be made.

**PRIMARY VOLTAGE FACILITIES:** Any facilities that involve voltage in excess of 600 volts.

**RACEWAY:** Any channel designed expressly and used solely for holding or enclosing conductors.

**RATE CLASS:** The definition of member/customer such as residential, general service, or irrigation, to which a specific rate is applied.

**REACTIVE METERING:** Measuring required to determine the power factor of the metered load.

**RECONNECT:** The re-energize electrical service.

**RIGHT-OF-WAY:** A strip of land authorized or identified for use by utilities.

**SEAL:** A locking device to prevent access or tampering of electrical equipment.

**SELF-CONTAINED METERING INSTALLATION:** A meter installation that does not require other devices such as current or potential transformers.

**SERVICE DROP:** The low voltage conductors between the electric supply and building or structure being served.

**SERVICE MAST:** The required parts and hardware to provide for electrical interconnection with the service drop and the member owned facilities which interconnect with the service entrance equipment with the building.

**SERVICE ENTRANCE EQUIPMENT:** The member supplied equipment that is necessary to interconnect with Fall River Electric.

**SERVICE LATERALS:** Conductors or circuits that extend from the utility's transformers.

**SERVICE TRENCH:** A trench dug to the Cooperative's specifications utilized for the placement of electrical conductors or conduits from the utility's transformer to the member's service entrance equipment.

**SITE PLAN:** A drawing that shows the building outline in relation to the property layout and reflects the point where electrical connections to the building will be made.

**SURFACE MOUNT:** A term used to describe any electrical equipment or material that is mounted to the surface of a structure.

**TEMPORARY SERVICE:** A metered electric service to be used during construction of new facilities or other purposes for a short period of time (normally not to exceed 90 days).

**TRANSFER SWITCH:** A permanently installed fail safe switch used to disconnect all conductors to Fall River Electric's system to a consumer load.

**TRANSFORMER:** A device used to increase or decrease voltage levels.

**TRANSFORMER PAD:** A concrete, fiberglass, or other solid material slab that is used to support a pad-mounted transformer.

**UNGROUNDING CONDUCTORS:** Any conductor that is not connected to ground.

**UNMETERED CONDUCTORS:** Any conductors attached to the utility's conductors ahead of the metering device and therefore providing electrical service without being recorded.

**WEATHERHEAD:** A conduit cap placed on the open end of a conduit through which conductors pass, which is constructed to prevent moisture from entering the conduit.



*Committed to safely and economically provide  
reliable energy and other services which  
bring value to its membership.*



Ashton, Idaho Headquarters Building



1150 N. 3400 E. Ashton, ID 83420  
[www.fallriverelectric.com](http://www.fallriverelectric.com) | 800.632.5726